



## **Catalyst 3850 Switch Hardware Installation Guide**

**First Published:** 2013-01-21

**Last Modified:** 2015-09-22

### **Americas Headquarters**

Cisco Systems, Inc.  
170 West Tasman Drive  
San Jose, CA 95134-1706  
USA  
<http://www.cisco.com>  
Tel: 408 526-4000  
800 553-NETS (6387)  
Fax: 408 527-0883

Text Part Number: OL-26779-05



# CONTENTS

---

**PREFACE**

**Preface** **xi**

- Document Conventions **xi**
- Related Documentation **xiii**
- Obtaining Documentation and Submitting a Service Request **xiii**

---

**CHAPTER 1**

**Product Overview** **1**

- Switch Models **1**
- Front Panel **6**
  - 10/100/1000 Ports **8**
  - PoE, PoE+, and Cisco UPoE Ports **8**
  - SFP and QSFP Module Slots **9**
  - Management Ports **9**
  - USB Type A Port **10**
  - Network Modules **11**
    - SFP and SFP+ Modules **13**
- LEDs **13**
  - SYST LED **16**
  - XPS LED **16**
  - Port LEDs and Modes **17**
  - USB Console LED **19**
  - S-PWR LED **19**
  - ACTV LED **20**
  - STACK LED **20**
  - PoE LED **21**
  - UID/Beacon LED **21**

Network Module LEDs	22
Rear Panel	22
RJ-45 Console Port LED	25
StackWise Ports	25
Power Supply Modules	25
Fan Module	28
StackPower Connector	30
Ethernet Management Port	30
RJ-45 Console Port	31
Management Options	31

---

**CHAPTER 2**
**Switch Installation 33**

Preparing for Installation	33
Safety Warnings	33
Installation Guidelines	35
Box Contents	36
Tools and Equipment	36
Verifying Switch Operation	36
Powering Off the Switch	36
Planning a Switch Data Stack	36
Switch Stacking and Power Stacking Guidelines	37
Data Stack Cabling Configurations	38
Data Stack Bandwidth and Partitioning Examples	38
Power-On Sequence for Switch Stacks	39
Planning a StackPower Stack	40
StackPower Stacking Guidelines	40
StackPower Cabling Configurations	41
StackPower Partitioning Examples	42
Installing the Switch	43
Rack-Mounting	43
Attaching the Rack-Mount Brackets	44
Mounting the Switch a Rack	46
Installing the Switch on a Table or Shelf	47
After Switch Installation	47

Connecting to the StackWise Ports	47
Connecting to the StackPower Ports	48
Installing a Network Module in the Switch	49
Installing and Removing SFP, SFP+ and QSFP+ Modules	49
Connecting Devices to the Ethernet Ports	49
10/100/1000 Port Connections	49
Auto-MDIX Connections	50
PoE+ and Cisco UPOE Port Connections	50
Where to Go Next	51

**CHAPTER 3**

<b>Installing a Network Module</b>	<b>53</b>
Network Module Overview	53
Network Module LEDs	57
Installing a Network Module in the Switch	58
Safety Warnings	58
Equipment That You Need	59
Installing Network Modules	59
Network Module Port Configurations	61
C3850-NM-4-1G Module	61
C3850-NM-4-10G Module	61
C3850-NM-2-10G Module	62
C3850-NM-8-10G Module	62
C3850-NM-2-40G Module	63
Removing a Network Module	64
Installing SFP and SFP+ Modules	65
Removing SFP and SFP+ Modules	66
Finding the Network Module Serial Number	67

**CHAPTER 4**

<b>Power Supply Installation</b>	<b>69</b>
Power Supply Module Overview	69
Installation Guidelines	72
Installing or Replacing an AC Power Supply	74
Installing a DC Power Supply	75
Equipment That You Need	76

Grounding the Switch	76
Installing the DC Power Supply in the Switch	78
Wiring the DC Input Power Source	79
Finding the Power Supply Module Serial Number	80

---

**CHAPTER 5****Installing the Fan 83**

Fan Module Overview	83
Installation Guidelines	84
Installing a Fan Module	85
Finding the Fan Module Serial Number	86

---

**CHAPTER 6****Configuring the Switch 87**

Configuring the Switch Using the Web User Interface	87
Setting up the Switch	87
Connecting to the Switch	87
Creating User Accounts	88
Choosing Setup Options	90
Configuring Basic Device Settings	90
Configuring Your Device Based on a Site Profile	92
Configuring Switch Wide Settings	101
Configuring VLAN Settings	101
Configure STP Settings	102
Configuring DHCP, NTP, DNS and SNMP Settings	103
Configuring Port Settings	105
Configuring the Switch Using the CLI	107
Accessing the CLI Through the Console Port	107
Connecting the RJ-45 Console Port	108
Connecting the USB Console Port	108
Installing the Cisco Microsoft Windows USB Device Driver	111
Installing the Cisco Microsoft Windows XP USB Driver	111
Installing the Cisco Microsoft Windows 2000 USB Driver	111
Installing the Cisco Microsoft Windows Vista and Windows 7 USB Driver	112
Uninstalling the Cisco Microsoft Windows USB Driver	112
Uninstalling the Cisco Microsoft Windows XP and 2000 USB Driver	112

Uninstalling the Cisco Microsoft Windows Vista and Windows 7 USB Driver 113

---

**CHAPTER 7****Troubleshooting 115**

- Diagnosing Problems 115
  - Switch POST Results 115
  - Switch LEDs 115
  - Switch Connections 115
    - Bad or Damaged Cable 115
    - Ethernet and Fiber-Optic Cables 116
    - Link Status 116
    - 10/100/1000 Port Connections 116
    - 10/100/1000 PoE+ Port Connections 116
    - SFP and SFP+ Module 117
    - Interface Settings 117
    - Ping End Device 117
    - Spanning Tree Loops 117
  - Switch Performance 118
    - Speed, Duplex, and Autonegotiation 118
    - Autonegotiation and Network Interface Cards 118
    - Cabling Distance 118
  - Clearing the Switch IP Address and Configuration 118
  - Replacing a Failed Data Stack Member 119

---

**APPENDIX A****Technical Specifications 121**

- Environmental and Physical Specifications 121
- Specifications for the Power Supplies, Switches, and Fan 123

---

**APPENDIX B****Connector and Cable Specifications 127**

- Connector Specifications 127
  - 10/100/1000 Ports (Including PoE) 127
  - SFP Module Connectors 127
- Console Port 128
- Cables and Adapters 129
  - StackWise Cables 129

SFP Module Cables	129
Cisco QSFP to SFP or SFP+ Adapter	130
Cable Pinouts	130
Console Port Adapter Pinouts	131



THE SPECIFICATIONS AND INFORMATION REGARDING THE PRODUCTS IN THIS MANUAL ARE SUBJECT TO CHANGE WITHOUT NOTICE. ALL STATEMENTS, INFORMATION, AND RECOMMENDATIONS IN THIS MANUAL ARE BELIEVED TO BE ACCURATE BUT ARE PRESENTED WITHOUT WARRANTY OF ANY KIND, EXPRESS OR IMPLIED. USERS MUST TAKE FULL RESPONSIBILITY FOR THEIR APPLICATION OF ANY PRODUCTS.

THE SOFTWARE LICENSE AND LIMITED WARRANTY FOR THE ACCOMPANYING PRODUCT ARE SET FORTH IN THE INFORMATION PACKET THAT SHIPPED WITH THE PRODUCT AND ARE INCORPORATED HEREIN BY THIS REFERENCE. IF YOU ARE UNABLE TO LOCATE THE SOFTWARE LICENSE OR LIMITED WARRANTY, CONTACT YOUR CISCO REPRESENTATIVE FOR A COPY.

The following information is for FCC compliance of Class A devices: This equipment has been tested and found to comply with the limits for a Class A digital device, pursuant to part 15 of the FCC rules. These limits are designed to provide reasonable protection against harmful interference when the equipment is operated in a commercial environment. This equipment generates, uses, and can radiate radio-frequency energy and, if not installed and used in accordance with the instruction manual, may cause harmful interference to radio communications. Operation of this equipment in a residential area is likely to cause harmful interference, in which case users will be required to correct the interference at their own expense.

The following information is for FCC compliance of Class B devices: This equipment has been tested and found to comply with the limits for a Class B digital device, pursuant to part 15 of the FCC rules. These limits are designed to provide reasonable protection against harmful interference in a residential installation. This equipment generates, uses and can radiate radio frequency energy and, if not installed and used in accordance with the instructions, may cause harmful interference to radio communications. However, there is no guarantee that interference will not occur in a particular installation. If the equipment causes interference to radio or television reception, which can be determined by turning the equipment off and on, users are encouraged to try to correct the interference by using one or more of the following measures:

- Reorient or relocate the receiving antenna.
- Increase the separation between the equipment and receiver.
- Connect the equipment into an outlet on a circuit different from that to which the receiver is connected.
- Consult the dealer or an experienced radio/TV technician for help.

Modifications to this product not authorized by Cisco could void the FCC approval and negate your authority to operate the product

The Cisco implementation of TCP header compression is an adaptation of a program developed by the University of California, Berkeley (UCB) as part of UCB's public domain version of the UNIX operating system. All rights reserved. Copyright © 1981, Regents of the University of California.

NOTWITHSTANDING ANY OTHER WARRANTY HEREIN, ALL DOCUMENT FILES AND SOFTWARE OF THESE SUPPLIERS ARE PROVIDED "AS IS" WITH ALL FAULTS. CISCO AND THE ABOVE-NAMED SUPPLIERS DISCLAIM ALL WARRANTIES, EXPRESSED OR IMPLIED, INCLUDING, WITHOUT LIMITATION, THOSE OF MERCHANTABILITY, FITNESS FOR A PARTICULAR PURPOSE AND NONINFRINGEMENT OR ARISING FROM A COURSE OF DEALING, USAGE, OR TRADE PRACTICE.

IN NO EVENT SHALL CISCO OR ITS SUPPLIERS BE LIABLE FOR ANY INDIRECT, SPECIAL, CONSEQUENTIAL, OR INCIDENTAL DAMAGES, INCLUDING, WITHOUT LIMITATION, LOST PROFITS OR LOSS OR DAMAGE TO DATA ARISING OUT OF THE USE OR INABILITY TO USE THIS MANUAL, EVEN IF CISCO OR ITS SUPPLIERS HAVE BEEN ADVISED OF THE POSSIBILITY OF SUCH DAMAGES.

Any Internet Protocol (IP) addresses and phone numbers used in this document are not intended to be actual addresses and phone numbers. Any examples, command display output, network topology diagrams, and other figures included in the document are shown for illustrative purposes only. Any use of actual IP addresses or phone numbers in illustrative content is unintentional and coincidental.

Cisco and the Cisco logo are trademarks or registered trademarks of Cisco and/or its affiliates in the U.S. and other countries. To view a list of Cisco trademarks, go to this URL: [www.cisco.com/go/trademarks](http://www.cisco.com/go/trademarks). Third-party trademarks mentioned are the property of their respective owners. The use of the word partner does not imply a partnership relationship between Cisco and any other company. (1721R)

© 2016 Cisco Systems, Inc. All rights reserved.





## Preface

- [Document Conventions](#) , on page xi
- [Related Documentation](#), on page xiii
- [Obtaining Documentation and Submitting a Service Request](#), on page xiii

## Document Conventions

This document uses the following conventions:

Convention	Description
<code>^</code> or <code>Ctrl</code>	Both the <code>^</code> symbol and <code>Ctrl</code> represent the Control ( <code>Ctrl</code> ) key on a keyboard. For example, the key combination <code>^D</code> or <code>Ctrl-D</code> means that you hold down the Control key while you press the D key. (Keys are indicated in capital letters but are not case sensitive.)
<b>bold font</b>	Commands and keywords and user-entered text appear in <b>bold font</b> .
<i>Italic font</i>	Document titles, new or emphasized terms, and arguments for which you supply values are in <i>italic font</i> .
<code>Courier font</code>	Terminal sessions and information the system displays appear in <code>courier font</code> .
<b>Bold Courier font</b>	<b>Bold Courier font</b> indicates text that the user must enter.
[x]	Elements in square brackets are optional.
...	An ellipsis (three consecutive nonbolded periods without spaces) after a syntax element indicates that the element can be repeated.
	A vertical line, called a pipe, indicates a choice within a set of keywords or arguments.
[x   y]	Optional alternative keywords are grouped in brackets and separated by vertical bars.
{x   y}	Required alternative keywords are grouped in braces and separated by vertical bars.

Convention	Description
[x {y   z}]	Nested set of square brackets or braces indicate optional or required choices within optional or required elements. Braces and a vertical bar within square brackets indicate a required choice within an optional element.
string	A nonquoted set of characters. Do not use quotation marks around the string or the string will include the quotation marks.
< >	Nonprinting characters such as passwords are in angle brackets.
[ ]	Default responses to system prompts are in square brackets.
!, #	An exclamation point (!) or a pound sign (#) at the beginning of a line of code indicates a comment line.

### Reader Alert Conventions

This document may use the following conventions for reader alerts:



**Note** Means *reader take note*. Notes contain helpful suggestions or references to material not covered in the manual.



**Tip** Means *the following information will help you solve a problem*.



**Caution** Means *reader be careful*. In this situation, you might do something that could result in equipment damage or loss of data.



**Timesaver** Means *the described action saves time*. You can save time by performing the action described in the paragraph.



### Warning

**IMPORTANT SAFETY INSTRUCTIONS**

This warning symbol means danger. You are in a situation that could cause bodily injury. Before you work on any equipment, be aware of the hazards involved with electrical circuitry and be familiar with standard practices for preventing accidents. Use the statement number provided at the end of each warning to locate its translation in the translated safety warnings that accompanied this device. Statement 1071

SAVE THESE INSTRUCTIONS

## Related Documentation



---

**Note** Before installing or upgrading the switch, refer to the switch release notes.

---

- Cisco Catalyst 3850 Series Switches documentation, located at:  
[http://www.cisco.com/go/cat3850\\_docs](http://www.cisco.com/go/cat3850_docs)
- Cisco Catalyst 3650 Series Switches documentation, located at:  
[http://www.cisco.com/go/cat3650\\_docs](http://www.cisco.com/go/cat3650_docs)
- Catalyst 2960-X Switch documentation, located at:  
[http://www.cisco.com/go/cat2960x\\_docs](http://www.cisco.com/go/cat2960x_docs)
- Cisco SFP and SFP+ modules documentation, including compatibility matrixes, located at:  
[http://www.cisco.com/en/US/products/hw/modules/ps5455/tsd\\_products\\_support\\_series\\_home.html](http://www.cisco.com/en/US/products/hw/modules/ps5455/tsd_products_support_series_home.html)
- Cisco SFP, SFP+, and QSFP+ modules documentation, including compatibility matrixes, located at:  
[http://www.cisco.com/en/US/products/hw/modules/ps5455/tsd\\_products\\_support\\_series\\_home.html](http://www.cisco.com/en/US/products/hw/modules/ps5455/tsd_products_support_series_home.html)
- Cisco Validated Designs documents, located at:  
<http://www.cisco.com/go/designzone>

## Obtaining Documentation and Submitting a Service Request

For information on obtaining documentation, submitting a service request, and gathering additional information, see the monthly *What's New in Cisco Product Documentation*, which also lists all new and revised Cisco technical documentation, at:

<http://www.cisco.com/c/en/us/td/docs/general/whatsnew/whatsnew.html>

Subscribe to the *What's New in Cisco Product Documentation* as a Really Simple Syndication (RSS) feed and set content to be delivered directly to your desktop using a reader application. The RSS feeds are a free service and Cisco currently supports RSS version 2.0.





# CHAPTER 1

## Product Overview

The Catalyst 3850 family of switches are Ethernet switches to which you can connect devices such as Cisco IP Phones, Cisco Wireless Access Points, workstations, and other network devices such as servers, routers, and other switches.

The Catalyst 3850 switches support stacking through Cisco StackWise-480 technology and power management through StackPower. The StackWise technology for the Catalyst 3850 switches is called StackWise-480.

Unless otherwise noted, the term switch refers to a standalone switch and to a switch stack.

This chapter contains these topics:

- [Switch Models, on page 1](#)
- [Front Panel, on page 6](#)
- [Rear Panel, on page 22](#)
- [Management Options, on page 31](#)

## Switch Models

*Table 1: Catalyst 3850 Switch Models and Descriptions*

Switch Model	Supported Software Image	Description
WS-C3850-24T-L	LAN Base	Stackable 24 10/100/1000 Ethernet ports, 1 network module slot, 350 W power supply
WS-C3850-48T-L	LAN Base	Stackable 48 10/100/1000 Ethernet ports, 1 network module slot, 350 W power supply
WS-C3850-24P-L	LAN Base	Stackable 24 10/100/1000 PoE+ <sup>2</sup> ports, 1 network module slot, 715 W power supply
WS-C3850-48P-L	LAN Base	Stackable 48 10/100/1000 PoE+ ports, 1 network module slot, 715 W power supply

Switch Model	Supported Software Image	Description
WS-C3850-48F-L	LAN Base	Stackable 48 10/100/1000 PoE+ ports, 1 network module slot, 1100 W power supply
WS-C3850-24U-L	LAN Base	Stackable 24 10/100/1000 Cisco UPOE <sup>3</sup> ports, 1 network module slot, 1100 W power supply
WS-C3850-48U-L	LAN Base	Stackable 48 10/100/1000 Cisco UPOE ports, 1 network module slot, 1100 W power supply
WS-C3850-12X48U-L	LAN Base	Stackable 12 100M/1G/2.5G/5G/10G and 36 1G UPoE ports, 1 network module slot, 1100 W power supply
WS-C3850-24XU-L	LAN Base	Stackable 24 100M/1G/2.5G/5G/10G UPoE ports, 1 network module slot, 1100-W power supply
WS-C3850-24T-S	IP Base	Stackable 24 10/100/1000 Ethernet ports, 1 network module slot, 350 W power supply
WS-C3850-48T-S	IP Base	Stackable 48 10/100/1000 Ethernet ports, 1 network module slot, 350 W power supply
WS-C3850-24P-S	IP Base	Stackable 24 10/100/1000 PoE+ ports, 1 network module slot, 715 W power supply
WS-C3850-48P-S	IP Base	Stackable 48 10/100/1000 PoE+ ports, 1 network module slot, 715 W power supply
WS-C3850-48F-S	IP Base	Stackable 48 10/100/1000 PoE+ ports, 1 network module slot, 1100 W power supply
WS-C3850-24U-S	IP Base	Stackable 24 10/100/1000 Cisco UPOE ports, 1 network module slot, 1100 W power supply
WS-C3850-48U-S	IP Base	Stackable 48 10/100/1000 Cisco UPOE ports, 1 network module slot, 1100 W power supply
WS-C3850-24PW-S	IP Base	Catalyst 3850 24-port PoE IP Base with 5 access points license

Switch Model	Supported Software Image	Description
WS-C3850-48PW-S	IP Base	Catalyst 3850 48-port PoE IP Base with 5 access points license
WS-C3850-12S-S	IP Base	Stackable 12 SFP module slots, 1 network module slot, 350 W power supply
WS-C3850-24S-S	IP Base	Stackable 24 SFP module slots, 1 network module slot, 350 W power supply
WS-C3850-12XS-S	IP Base	Catalyst 3850 12-port SFP+ transceiver, 1 network module slot, support for up to 10 G SFP+, 350 W power supply
WS-C3850-16XS-S	IP Base	Catalyst 3850 16-port SFP+ transceiver, 1 network module slot, support for up to 10 G SFP+, 350 W power supply.  16 ports are available when the C3850-NM-4-10G network module is plugged into the WS-C3850-12XS-S switch.
WS-C3850-24XS-S	IP Base	Catalyst 3850 24-port SFP+ transceiver, 1 network module slot, support for up to 10 G SFP+, 715 W power supply.
WS-C3850-32XS-S	IP Base	Catalyst 3850 32-port SFP+ transceiver, 1 network module slot, support for up to 10 G SFP+, 715 W power supply.  32 ports are available when the C3850-NM-8-10G network module is plugged into the WS-C3850-24XS-S switch.
WS-C3850-48XS-S	IP Base	Catalyst 3850 switch with SFP+ transceivers, 48 ports that support up to 10 G, and 4 QSFP ports that support up to 40 G. 750 W power supply. <sup>4</sup>  The airflow direction for this switch is from the front panel to the rear panel.

Switch Model	Supported Software Image	Description
WS-C3850-48XS-F-S	IP Base	Catalyst 3850 switch with SFP+ transceivers, 48 ports that support up to 10 G, and 4 QSFP ports that support up to 40 G. 750 W power supply.  The airflow direction for this switch is from the rear panel to the front panel.
WS-C3850-12X48U-S	IP Base	Stackable 12 100M/1G/2.5G/5G/10G and 36 1 G UPoE ports, 1 network module slot, 1100 W power supply
WS-C3850-12X48UW-S	IP Base	Stackable 12 100M/1G/2.5G/5G/10G and 36 1 G UPoE ports, 1 network module slot, 1100 W power supply
WS-C3850-24XU-S	IP Base	Stackable 24 100M/1G/2.5G/5G/10G UPoE ports, 1 network module slot, 1100-W power supply
WS-C3850-24XUW-S	IP Base	Stackable 24 100M/1G/2.5G/5G/10G UPoE ports, 1 network module slot, 1100-W power supply
WS-C3850-24T-E	IP Services	Stackable 24 10/100/1000 Ethernet ports, 1 network module slot, 350 W power supply
WS-C3850-48T-E	IP Services	Stackable 48 10/100/1000 Ethernet ports, 1 network module slot, 350 W power supply
WS-C3850-24P-E	IP Services	Stackable 24 10/100/1000 PoE+ ports, 1 network module slot, 715 W power supply
WS-C3850-48P-E	IP Services	Stackable 48 10/100/1000 PoE+ ports, 1 network module slot, 715 W power supply
WS-C3850-48F-E	IP Services	Stackable 48 10/100/1000 PoE+ ports, 1 network module slot, 1100 W power supply

Switch Model	Supported Software Image	Description
WS-C3850-24U-E	IP Services	Stackable 24 10/100/1000 Cisco UPOE ports, 1 network module slot, 1100 W power supply
WS-C3850-48U-E	IP Services	Stackable 48 10/100/1000 Cisco UPOE ports, 1 network module slot, 1100 W power supply
WS-C3850-12S-E	IP Services	Stackable 12 SFP module slots, 1 network module slot, 350 W power supply
WS-C3850-24S-E	IP Services	Stackable 24 SFP module slots, 1 network module slot, 350 W power supply
WS-C3850-12XS-E	IP Services	Catalyst 3850 12-port SFP+ transceiver, 1 network module slot, support for up to 10 G SFP+, 350 -W power supply.
WS-C3850-16XS-E	IP Services	Catalyst 3850 16-port SFP+ transceiver, 1 network module slot, support for up to 10 G SFP+, 350 W power supply.  16 ports are available when the C3850-NM-4-10G network module is plugged into the WS-C3850-12XS-E switch.
WS-C3850-24XS-E	IP Services	Catalyst 3850 24-port SFP+ transceiver, 1 network module slot, support for up to 10 G SFP+, 715 W power supply.
WS-C3850-32XS-E	IP Services	Catalyst 3850 32-port SFP+ transceiver, 1 network module slot, support for up to 10 G SFP+, 715 W power supply.  32 ports are available when the C3850-NM-8-10G network module is plugged into the WS-C3850-24XS-E switch.

Switch Model	Supported Software Image	Description
WS-C3850-48XS-E	IP Services	Catalyst 3850 switch with SFP+ transceivers, 48 ports that support up to 10 G, and 4 QSFP ports that support up to 40 G. 750 W power supply.  The airflow direction for this switch is from the front panel to the rear panel.
WS-C3850-48XS-F-E	IP Services	Catalyst 3850 switch with SFP+ transceivers, 48 ports that support up to 10 G, and 4 QSFP ports that support up to 40 G. 750 W power supply.  The airflow direction for this switch is from the rear panel to the front panel.
WS-C3850-12X48U-E	IP Services	Stackable 12 100M/1G/2.5G/5G/10G and 36 1 G UPoE ports, 1 network module slot, 1100 W power supply
WS-C3850-24XU-E	IP Services	Stackable 24 100M/1G/2.5G/5G/10G UPoE ports, 1 network module slot, 1100-W power supply

<sup>1</sup> For supported network modules, see [Network Modules, on page 11](#) .

<sup>2</sup> PoE+ = Power over Ethernet plus (provides up to 30 W per port).

<sup>3</sup> UPOE = Universal Power Over Ethernet (provides up to 60 W Cisco UPOE per port)

<sup>4</sup> The WS-C3850-48XS switches do not support StackWise-480

## Front Panel

This section describes the front panel components:

- 24 or 48 downlink ports of one of these types:
  - 10/100/1000
  - 10/100/1000 PoE+
  - 10/100/1000 Cisco UPoE
  - 10 G SFP+
- 12 or 24 SFP or SFP+ module downlink slots
- Uplink network modules slot
- USB Type A connector
- USB mini-Type B (console) port

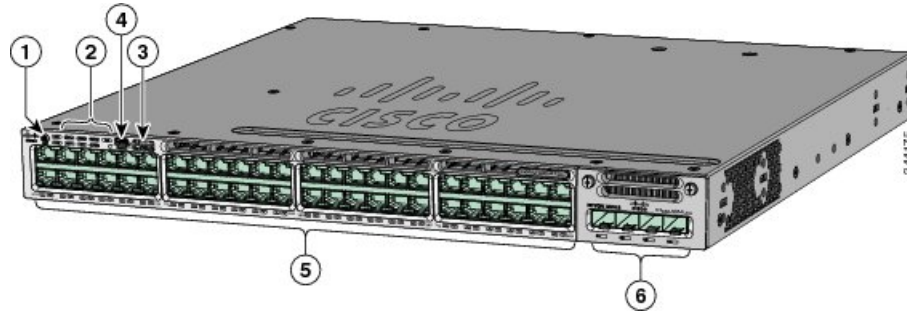
- LEDs
- Mode button

All of the switches have similar components. See the following illustrations for examples.



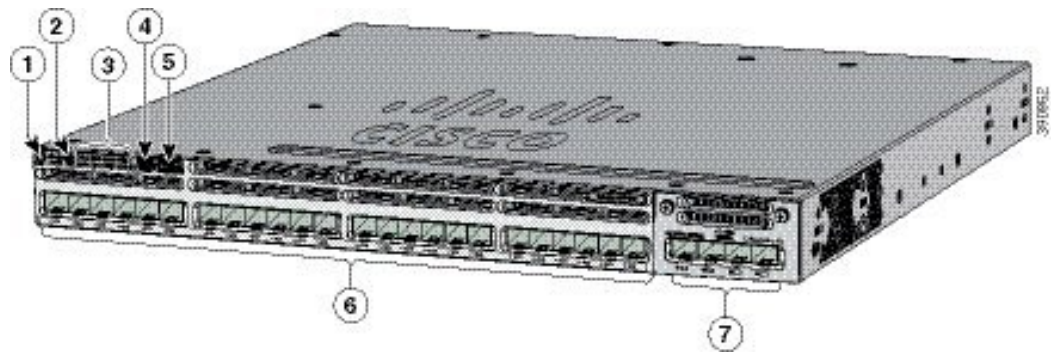
**Note** The Catalyst 3850 switches might have slight cosmetic differences on the bezels.

**Figure 1: WS-C3850-48P-L Switch Front Panel**



1	Mode button	4	USB mini-Type B (console) port
2	Status LEDs	5	10/100/1000 PoE+ ports
3	USB Type A storage port	6	Network module

**Figure 2: WS-C3850-24S Switch Front Panel**

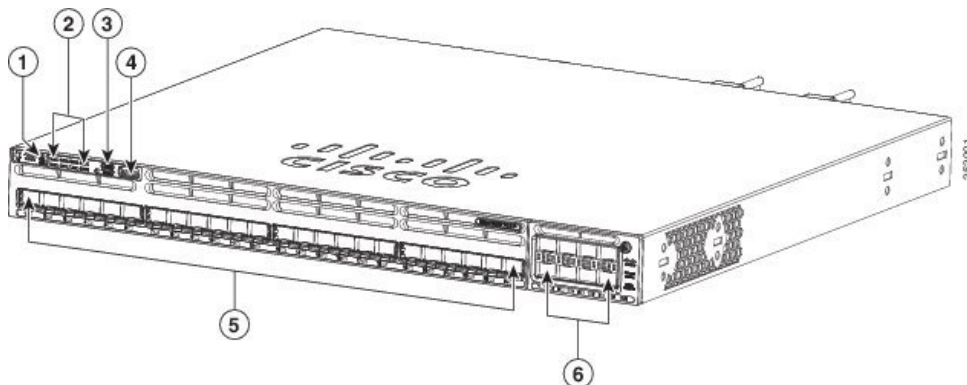


**Note** The WS-C3850-12S switches have similar front panels.

1	UID button	5	USB Type A storage port
2	Mode button	6	SFP module slots (downlink)
3	Status LEDs	7	Network module

4	USB mini-Type B (console) port		
---	--------------------------------	--	--

Figure 3: WS-C3850-24XS-E Switch Front Panel



**Note** The WS-C3850-24XS-E switches have the following components.

1	Mode button	4	USB mini-Type B (console) port
2	Status LEDs	5	10 G SFP+ ports
3	USB Type A storage port	6	Network module

## 10/100/1000 Ports

The 10/100/1000 ports use RJ-45 connectors with Ethernet pinouts. The maximum cable length is 328 feet (100 meters). The 10BASE-T, 100BASE-TX, 1000BASE-T traffic requires Category 5 or Category 5e twisted pair (UTP) cable. The 10BASE-T traffic can use Category 3 or Category 4 UTP cable.

## PoE, PoE+, and Cisco UPoE Ports

The PoE+ and Cisco Universal Power Over Ethernet (Cisco UPoE) ports use the same connectors as described in [10/100/1000 Port Connections](#), on page 49. They provide:

- PoE+ ports: Support for IEEE 802.3af-compliant powered devices (up to 15.4 W PoE per port) and support for IEEE 802.3at-compliant powered devices (up to 30 W PoE+ per port). The maximum total PoE power in a 1RU switch is 1800 W.
- Support for Cisco-enhanced PoE.
- Support for prestandard Cisco powered devices.
- Configuration for StackPower. When the switch internal power supply module(s) cannot support the total load, StackPower configurations allow the switch to leverage power available from other switches.
- Configurable support for Cisco intelligent power management, including enhanced power negotiation, power reservation, and per-port power policing.

Depending on the installed power supply modules, each port can deliver up to 60 W of Cisco UPOE. See the [Power Supply Modules, on page 25](#) for the power supply matrix that defines the available PoE, PoE+, and Cisco UPOE power per port. The output of the PoE+ circuit has been evaluated as a Limited Power Source (LPS) per IEC 60950-1.



---

**Note** Restrictions for the WS-C3850-12X48U-L, WS-C3850-12X48U-S and WS-C3850-12X48U-E switch models:

- A maximum of 28 ports are available for UPOE connections. This is because some power from the power supplies is diverted to the switch, and only the remaining power is transmitted to the ports.

---

## SFP and QSFP Module Slots

The uplink and downlink ports for the Catalyst WS-C3850 switch models are as follows.

- The downlink ports on the Catalyst WS-C3850-12S and WS-C3850-24S switch models support standard SFP modules.
- The downlink ports on the Catalyst WS-C3850-12XS and WS-C3850-24XS switch models support standard SFP+ modules.
- The 10G downlink ports on the Catalyst WS-C3850-48XS-S, WS-C3850-48XS-F-S, WS-C3850-48XS-E and WS-C3850-48XS-F-E switch models support standard SFP+ modules.
- The 40G downlink ports on the Catalyst WS-C3850-48XS-S, WS-C3850-48XS-F-S, WS-C3850-48XS-E and WS-C3850-48XS-F-E switch models support standard QSFP modules.

For supported SFP modules, refer to the Cisco Transceiver Modules Compatibility Information at [http://www.cisco.com/en/US/products/hw/modules/ps5455/products\\_device\\_support\\_tables\\_list.html](http://www.cisco.com/en/US/products/hw/modules/ps5455/products_device_support_tables_list.html)



---

**Note** For information about the (uplink) SFP module slots on the network modules, see [Network Modules, on page 11](#).

---

## Management Ports

The management ports connect the switch to a PC running Microsoft Windows or to a terminal server.

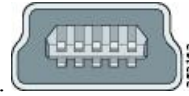
- Ethernet management port. See [Ethernet Management Port, on page 30](#).
- RJ-45 console port (EIA/TIA-232). See [RJ-45 Console Port, on page 31](#).
- USB mini-Type B console port (5-pin connector).

The 10/100/1000 Ethernet management port connection uses a standard RJ-45 crossover or straight-through cable. The RJ-45 console port connection uses the supplied RJ-45-to-DB-9 female cable. The USB console port connection uses a USB Type A to 5-pin mini-Type B cable. The USB console interface speeds are the same as the RJ-45 console interface speeds.

If you use the USB mini-Type B console port, the Cisco Windows USB device driver must be installed on any PC connected to the console port (for operation with Microsoft Windows). Mac OS X or Linux do not require special drivers.

The 4-pin mini-Type B connector resembles the 5-pin mini-Type B connectors. They are not compatible. Use only the 5-pin mini-Type B.

**Figure 4: USB Mini-Type B Port**



This illustration shows a 5-pin mini-Type B USB port.

With the Cisco Windows USB device driver, you can connect and disconnect the USB cable from the console port without affecting Windows HyperTerminal operations.

The console output always goes to both the RJ-45 and the USB console connectors, but the console input is active on only one of the console connectors at any one time. The USB console takes precedence over the RJ-45 console. When a cable is connected into the USB console port, the RJ-45 console port becomes inactive. Conversely, when the USB cable is disconnected from the USB console port, the RJ-45 port becomes active.

You can use the command-line interface (CLI) to configure an inactivity timeout which reactivates the RJ-45 console if the USB console has been activated and no input activity has occurred on the USB console for a specified time.

After the USB console deactivates due to inactivity, you cannot use the CLI to reactivate it. Disconnect and reconnect the USB cable to reactivate the USB console. For information on using the CLI to configure the USB console interface, see the software guide.

## USB Type A Port

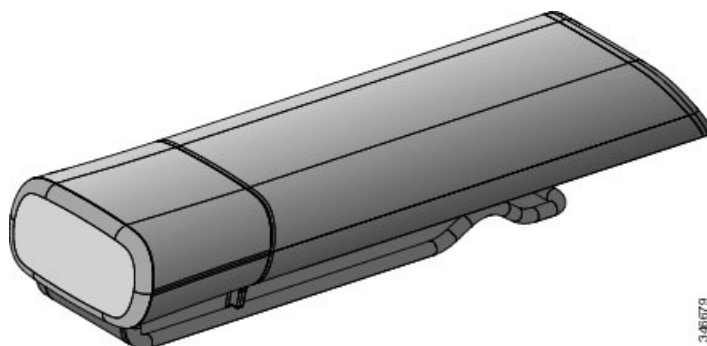
The USB Type A port provides access to external USB flash devices (also known as thumb drives or USB keys) and to specific Cisco USB Bluetooth devices.

The port supports Cisco USB flash drives with capacities from 128 MB to 8 GB (USB devices with port densities of 128 MB, 256 MB, 1 GB, 4 GB, and 8 GB are supported). When combined with stacking, you can upgrade other switches in the stack from an USB key inserted in any switch within the stack. Cisco IOS software provides standard file system access to the flash device: read, write, erase, and copy, as well as the ability to format the flash device with a FAT file system.

It provides you with the ability to automatically upgrade the internal flash with the USB drive's configuration and image for emergency switch recovery using USB auto-upgrade. This feature checks the internal flash for a bootable image and configuration and if either image or the configuration is not available, then the USB drive is checked for boot images and configuration. If the boot image and configuration are available, these are copied to flash for the reboot.

The port supports Cisco USB Bluetooth devices. The USB Bluetooth device acts as a Bluetooth host and serves as either a serial port or a management port connection. You can pair it with your Bluetooth smart phone, laptop, or tablet. If you configure the serial profile on the Bluetooth device, the switch turns the USB port into a serial port. If you configure the Personal Area Network (PAN) profile on the Bluetooth device, the switch turns the USB port into a management interface.

Figure 5: Cisco USB Bluetooth



## Network Modules

The switch supports one hot-swappable network module that provides uplink ports to connect to other devices. The switch should only be operated with either a network module or a blank module installed.

The switch generates logs when you insert or remove a network module with SFP ports.

Table 2: Network Modules

Network Module <sup>5</sup>	Description
C3850-NM-4-1G	<p>This module has four 1 G SFP module slots. Any combination of standard SFP modules are supported. SFP+ modules are not supported.</p> <p>If you insert an SFP+ module in the 1 G network module, the SFP+ module does not operate, and the switch logs an error message.</p> <p><b>Note</b> This is supported on the following switch models:</p> <ul style="list-style-type: none"> <li>• WS-C3850-24T/P/U</li> <li>• WS-C3850-48T/F/P/U</li> <li>• WS-C3850-12X48U</li> <li>• WS-C3850-24XU</li> <li>• WS-C3850-12S</li> <li>• WS-C3850-24S</li> </ul>

Network Module <sup>5</sup>	Description
C3850-NM-2-10G	<p>This module has four slots:</p> <p>Two slots (left side) support only 1 G SFP modules and two slots (right side) support either 1 G SFP or 10 G SFP modules.</p> <p><b>Note</b> This is supported on the following switch models:</p> <ul style="list-style-type: none"> <li>• WS-C3850-24T/P/U</li> <li>• WS-C3850-48T/F/P/U</li> <li>• WS-C3850-12X48U</li> <li>• WS-C3850-24XU</li> <li>• WS-C3850-12S</li> <li>• WS-C3850-24S</li> </ul>
C3850-NM-4-10G	<p>This module has four 10 G slots or four 1 G slots.</p> <p><b>Note</b> This is supported on the following switch models:</p> <ul style="list-style-type: none"> <li>• WS-C3850-48T/F/P/U</li> <li>• WS-C3850-12X48U</li> <li>• WS-C3850-24XU</li> <li>• WS-C3850-12XS</li> <li>• WS-C3850-24XS</li> </ul>
C3850-NM-8-10G	<p>This module has eight 10 G slots with an SFP+ port in each slot. Each port supports a 1 G or 10 G connection</p> <p><b>Note</b> This is supported on the following switch models:</p> <ul style="list-style-type: none"> <li>• WS-C3850-12X48U</li> <li>• WS-C3850-24XU</li> <li>• WS-C3850-24XS</li> </ul>
C3850-NM-2-40G	<p>This module has two 40 G slots with a QSFP+ connector in each slot.</p> <p><b>Note</b> This is supported on the following switch models:</p> <ul style="list-style-type: none"> <li>• WS-C3850-12X48U</li> <li>• WS-C3850-24XU</li> <li>• WS-C3850-24XS</li> </ul>
C3850-NM-BLANK	<p>Insert this blank module when the switch has no uplink ports (this is required for sufficient air flow).</p>

<sup>5</sup> All network modules are hot-swappable.

For information about the network modules, see the [Installing Network Modules, on page 59](#). For cable specifications, see [Cables and Adapters, on page 129](#).

## SFP and SFP+ Modules

The SFP and SFP+ modules provide copper or fiber-optic connections to other devices. These transceiver modules are field-replaceable, and they provide the uplink interfaces (except in the fixed SFP slots in the WS-C3850-12S and WS-C3850-24S switches) when installed in an SFP module slot. The SFP modules have LC connectors for fiber-optic connections or RJ-45 connectors for copper connections.



---

**Note** The downlink ports on the Catalyst WS-C3850-12S and WS-C3850-24S switch models support standard SFP modules, and the downlink ports on the Catalyst WS-C3850-12XS and WS-C3850-24XS switch models support standard SFP+ modules.

---

Use only Cisco SFP and SFP+ modules on the switch. For the latest information about supported SFP and SFP+ modules, refer to the Cisco Transceiver Modules Compatibility Information at [http://www.cisco.com/en/US/products/hw/modules/ps5455/products\\_device\\_support\\_tables\\_list.html](http://www.cisco.com/en/US/products/hw/modules/ps5455/products_device_support_tables_list.html)

For information about SFP modules, see the documentation at [Installing SFP and SFP+ Modules, on page 65](#).

The Catalyst 3850 switch supports the SFP module patch cable (CAB-SFP-50CM), a 0.5-meter, copper, passive cable with SFP module connectors at each end. This cable is only used with 1-Gigabit Ethernet SFP ports to connect two Catalyst 3850 switches in a cascaded configuration.

For information about QSFP modules, see the documentation at

- [QSFP Port Cabling Specifications](#)
- [Cisco S-Class 40GBASE QSFP Modules Data Sheet](#)

## LEDs

You can use the switch LEDs to monitor switch activity and its performance.



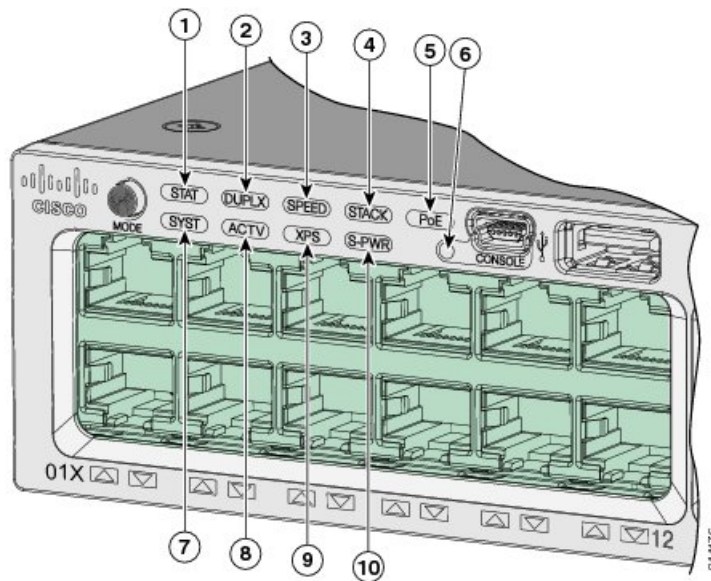
---

**Note** Catalyst 3850 switches might have slight cosmetic differences on the bezels.

---

**Figure 6: Switch Front Panel LEDs**

This figure shows the switch LEDs and the Mode button that you use to select a port mode.

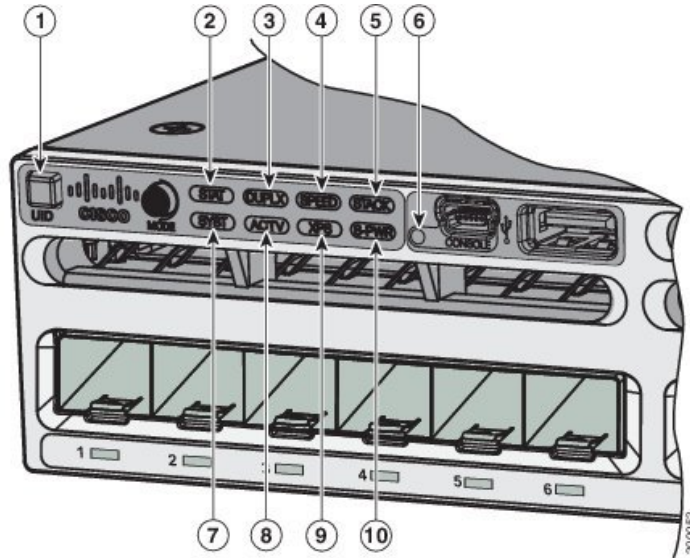


1	STAT (status)	6	USB mini-Type B console port LED
2	DUPLX (duplex)	7	SYST (system)
3	SPEED	8	ACTV (active)
4	STACK	9	XPS <sup>6</sup>
5	PoE	10	S-PWR (StackPower)

<sup>6</sup> XPS = expandable power system.

<sup>7</sup> Only on switch models that support PoE.

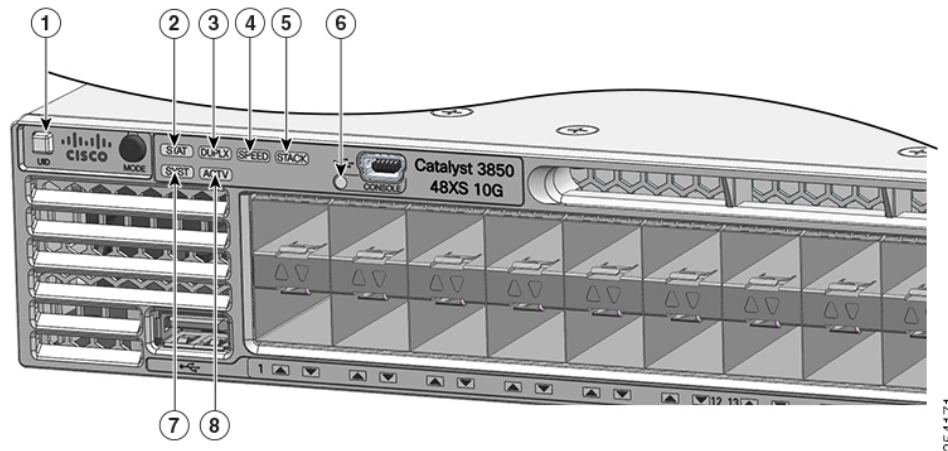
Figure 7: Switch Front Panel LEDs for the WS-C3850-12S, WS-C3850-24S, WS-C3850-12XS, and WS-C3850-24XS Switches



1	UID (blue beacon)	6	USB mini-Type B console port LED
2	STAT (status)	7	SYST (system)
3	DUPLX (duplex)	8	ACTV (active)
4	SPEED	9	XPS <sup>8</sup>
5	STACK	10	S-PWR (StackPower)

<sup>8</sup> XPS = expandable power system.

Figure 8: Switch Front Panel LEDs for the WS-C3850-48XS Switches



1	UID (blue beacon)	5	STACK
2	STAT (status)	6	USB mini-Type B console port LED
3	DUPLX (duplex)	7	SYST (system)
4	SPEED	8	ACTV (active)

## SYST LED

**Table 3: SYST LED**

Color	System Status
Off	System is not powered on.
Green	System is operating normally.
Blinking green	POST in progress.
Amber	System is receiving power but is not functioning properly.
Blinking amber	There is a fault with one of the following: <ul style="list-style-type: none"> <li>• Network module (non traffic-related)</li> <li>• Power supply</li> <li>• Fan module</li> </ul>

## XPS LED

**Table 4: XPS LED**

Color	Description
Off	XPS cable is not installed. Switch is in StackPower mode.
Green	XPS is connected and ready to provide back-up power.
Blinking green	XPS is connected but is unavailable because it is providing power to another device (redundancy has been allocated to a neighboring device).
Amber	The XPS is in standby mode or in a fault condition. See the XPS 2200 documentation for information about the standby mode and fault conditions.
Blinking amber	The power supply in a switch has failed, and the XPS is providing power to that switch (redundancy has been allocated to this device).

For information about the XPS 2200, see the *Cisco eXpandable Power System 2200 Hardware Installation Guide* on Cisco.com:

[http://www.cisco.com/go/xps2200\\_hw](http://www.cisco.com/go/xps2200_hw)

## Port LEDs and Modes

Each Ethernet port, 1-Gigabit Ethernet module slot, and 10-Gigabit Ethernet module slot has a port LED. These port LEDs, as a group or individually, display information about the switch and about the individual ports. The port mode determines the type of information shown by the port LEDs.

To select or change a mode, press the Mode button until the desired mode is highlighted. When you change port modes, the meanings of the port LED colors also change.

When you press the Mode button on any switch in the switch stack, all the stack switches change to show the same selected mode. For example, if you press the Mode button on the active switch to show the SPEED LED, all the other switches in the stack also show the SPEED LED.

**Table 5: Port Mode LEDs**

Mode LED	Port Mode	Description
STAT	Port status	The port status. This is the default mode.
SPEED	Port speed	The port operating speed: 10, 100, or 1000 Mb/s.
DUPLX	Port duplex mode	The port duplex mode: full duplex or half duplex.
ACTV	Active	The active switch status.
STACK	Stack member status StackWise port status	Stack member status. The StackWise port status. See <a href="#">STACK LED, on page 20</a> .
PoE <sup>9</sup>	The PoE+ port status.	The PoE+ port status.

<sup>9</sup> Only switches with PoE+ ports.

**Table 6: Meaning of Switch LED Colors in Different Modes**

Port Mode	Port LED Color	Meaning
STAT (port status)	Off	No link, or port was administratively shut down.
	Green	Link present, no activity.
	Blinking green	Activity. Port is sending or receiving data.
	Alternating green-amber	Link fault. Error frames can affect connectivity, and errors such as excessive collisions, CRC errors, and alignment and jabber errors are monitored for a link-fault indication.
	Amber	Port is blocked by Spanning Tree Protocol (STP) and is not forwarding data.  After a port is reconfigured, the port LED can be amber for up to 30 seconds as STP checks the switch for possible loops.

Port Mode	Port LED Color	Meaning
SPEED	<b>10/100/1000/SFP ports</b>	
	Off	Port is operating at 10 Mb/s.
	Green	Port is operating at 100 Mb/s.
	Single green flash (on for 100 ms, off for 1900 ms)	Port is operating at 1000 Mb/s.
	Blinking twice	Port is operating at 2500, 5000 or 10000 Mb/s
	<b>Network module slots</b>	
	Off	Port is not operating.
	Blinking green	Port is operating at up to 10 Gb/s.
DUPLX (duplex)	Off	Port is operating in half duplex.
	Green	Port is operating in full duplex.
ACTV (data active switch)	Off	The switch is not the active switch. <b>Note</b> For a standalone switch, this LED is off.
	Green	The switch is the active switch.
	Amber	Error during active switch election.
	Blinking green	Switch is a standby member of a data stack and assumes active responsibilities if the current active switch fails.
STACK (stack member)	Off	No stack member corresponding to that member number.
	Blinking green	Stack member number.
	Green	Member numbers of other stack member switches.

Port Mode	Port LED Color	Meaning
PoE+ <sup>10</sup>	Off	PoE+ is off.  If the powered device is receiving power from an AC power source, the port LED is off even if the device is connected to the switch port.
	Green	PoE+ is on. The port LED is green when the switch port is providing power.
	Alternating green-amber	PoE+ is denied because providing power to the powered device will exceed the switch power capacity.
	Blinking amber	PoE+ is off due to a fault or because it has exceeded a limit set in the switch software.  <b>Caution</b> PoE+ faults occur when noncompliant cabling or powered devices are connected to a PoE+ port. Use only standard-compliant cabling to connect Cisco prestandard IP Phones and wireless access points or IEEE 802.3af-compliant devices to PoE+ ports. You must remove from the network any cable or device that causes a PoE+ fault.
	Amber	PoE+ for the port has been disabled.  <b>Note</b> PoE+ is enabled by default.

<sup>10</sup> Only switches with PoE or PoE+ ports.

## USB Console LED

The USB console LED shows whether there is an active USB connection to the port.

**Table 7: USB Console LED**

LED	Color	Description
USB console port	Green	USB console port is active.
	Off	The USB is disabled.

## S-PWR LED

**Table 8: S-PWR LED**

Color	Description
Off	StackPower cable is not connected, or the switch is in standalone mode.
Green	Each StackPower port is connected to another switch.

Color	Description
Blinking green	This appears on the switch in a StackPower ring configuration that detects an open ring or has only one StackPower cable connected.
Amber	There is a fault: load shedding is occurring, a StackPower cable is defective, or an administrative action is required. See the switch software configuration guide for information about configuring StackPower.
Blinking amber	The StackPower budget is not sufficient to meet current power demands.

## ACTV LED

**Table 9: ACTV LED**

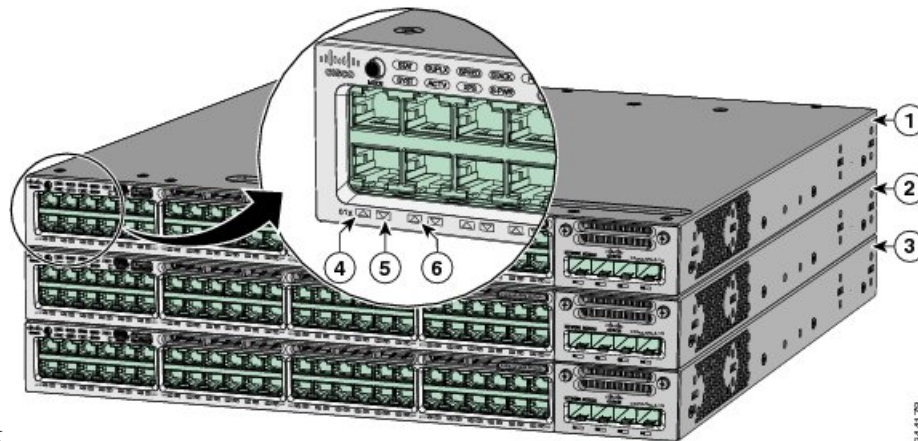
Color	Description
Off	Switch is not the active switch.
Green	Switch is the active switch or a standalone switch.
Slow blinking green	Switch is in stack standby mode.
Amber	An error occurred when the switch was selecting the active switch, or another type of stack error occurred.

## STACK LED

The STACK LED shows the sequence of member switches in a stack. Up to nine switches can be members of a stack. The first nine port LEDs show the member number of a switch in a stack.

**Figure 9: STACK LED**

This figure shows the LEDs on for each switch. When you press the Mode button to select the STACK LED, the corresponding port LEDs will blink green for each switch. For example, for switch 1, port 1 will blink green and the rest of the LEDs will be off. On switch 2, port 2 will blink green and the rest of the LEDs will be off. The same behavior will be seen with the remaining switches in the



stack.

344178

1	Stack member 1	4	LED blinks green to show that this is switch 1 in the stack.
2	Stack member 2	5	LED blinks green to show that this is switch 2 in the stack.
3	Stack member 3	6	LED blinks green to show that this is switch 3 in the stack.

## PoE LED

The PoE LED indicates the status of the PoE mode: either PoE, PoE+, or Cisco UPOE.

**Table 10: PoE LED**

Color	Description
Off	PoE mode is not selected. None of the 10/100/1000 ports have been denied power or are in a fault condition.
Green	PoE mode is selected, and the port LEDs show the PoE mode status.
Blinking amber	PoE mode is not selected. At least one of the 10/100/1000 ports has been denied power, or at least one of the 10/100/1000 ports has a PoE mode fault.

## UID/Beacon LED

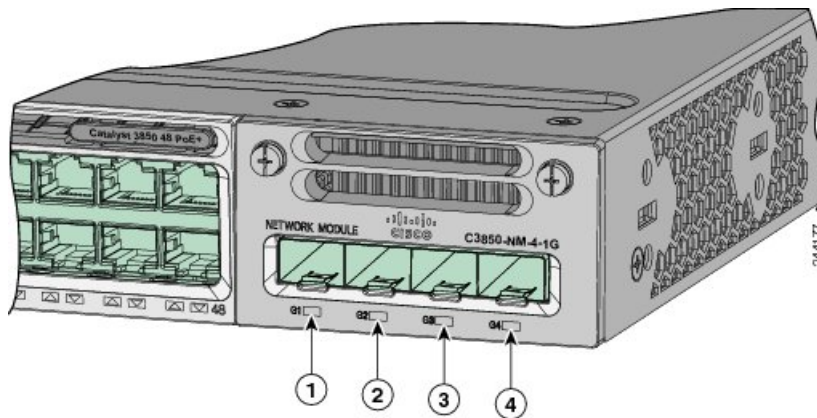
The UID and the Beacon LED can be turned on by the administrator to indicate that the switch needs attention. It helps the administrator identify the switch. The beacon can be turned on by either pressing the UID button on the switch front panel, or by using the CLI. There is a blue beacon on the front and rear panel of the switch. The blue beacon on the front panel is a button labeled UID, and on the back panel it is a LED labeled BEACON.

**Table 11: UID/Beacon LED Indicator (Applies Only to the WS-C3850-12S, WS-C3850-24S, WS-C3850-12XS, and WS-C3850-24XS Switches)**

Color/State	Description
Solid blue	The operator has indicated that the system needs attention.

## Network Module LEDs

Figure 10: Network Module LEDs



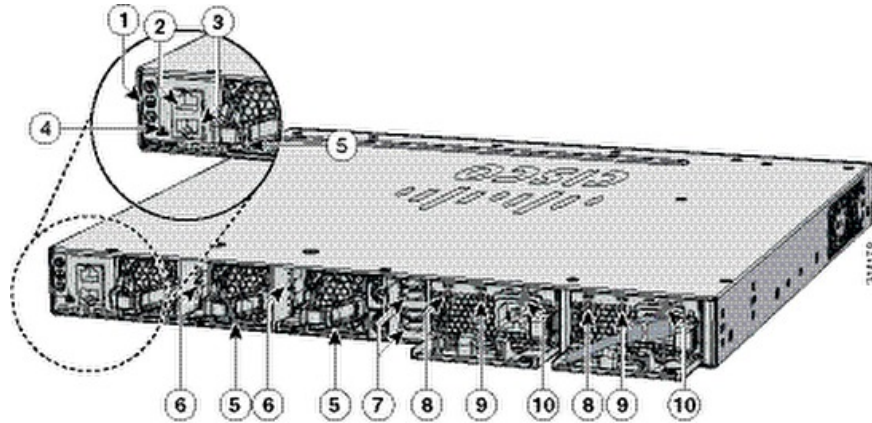
1	G1 LED	3	G3 LED
2	G2 LED	4	G4 LED

Color	Network Module Link Status
Off	Link is off.
Green	Link is on; no activity.
Blinking green	Activity on a link; no faults. <b>Note</b> The LED will blink green even when there is very little control traffic.
Blinking amber	Link is off due to a fault or because it has exceeded a limit set in the switch software. <b>Caution</b> Link faults occur when noncompliant cabling is connected to an SFP/SFP+ port. Use only standard-compliant cabling to connect to Cisco SFP/SFP+ ports. You must remove from the network any cable or device that causes a link fault.
Amber	Link for the SFP/SFP+ has been disabled.

## Rear Panel

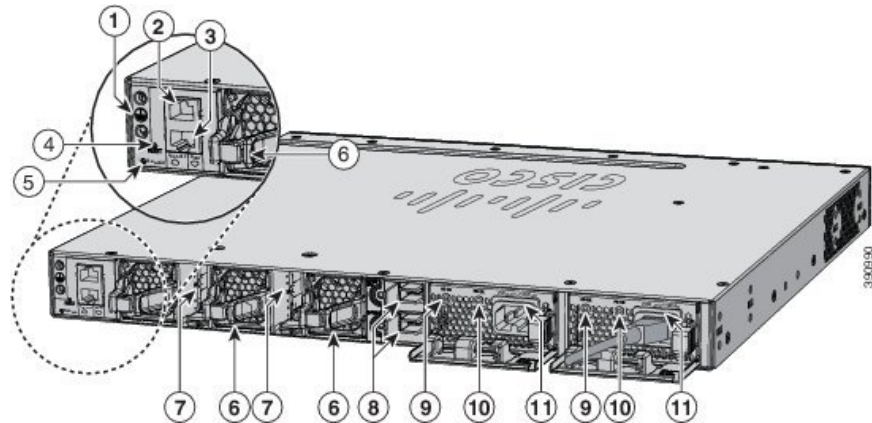
The switch rear panel includes StackWise connectors, StackPower or XPS 2200 connectors, ports, fan modules, and power supply modules.

Figure 11: Catalyst 3850 Switch Rear Panel



1	Ground connector	6	StackWise port connector
2	CONSOLE (RJ-45 console port)	7	StackPower connector
3	MGMT (RJ-45 10/100/1000 management port)	8	AC OK (input) status LED
4	RESET button	9	PS OK (output) status LED
5	Fan module	10	Power supply modules (AC power supply modules shown)

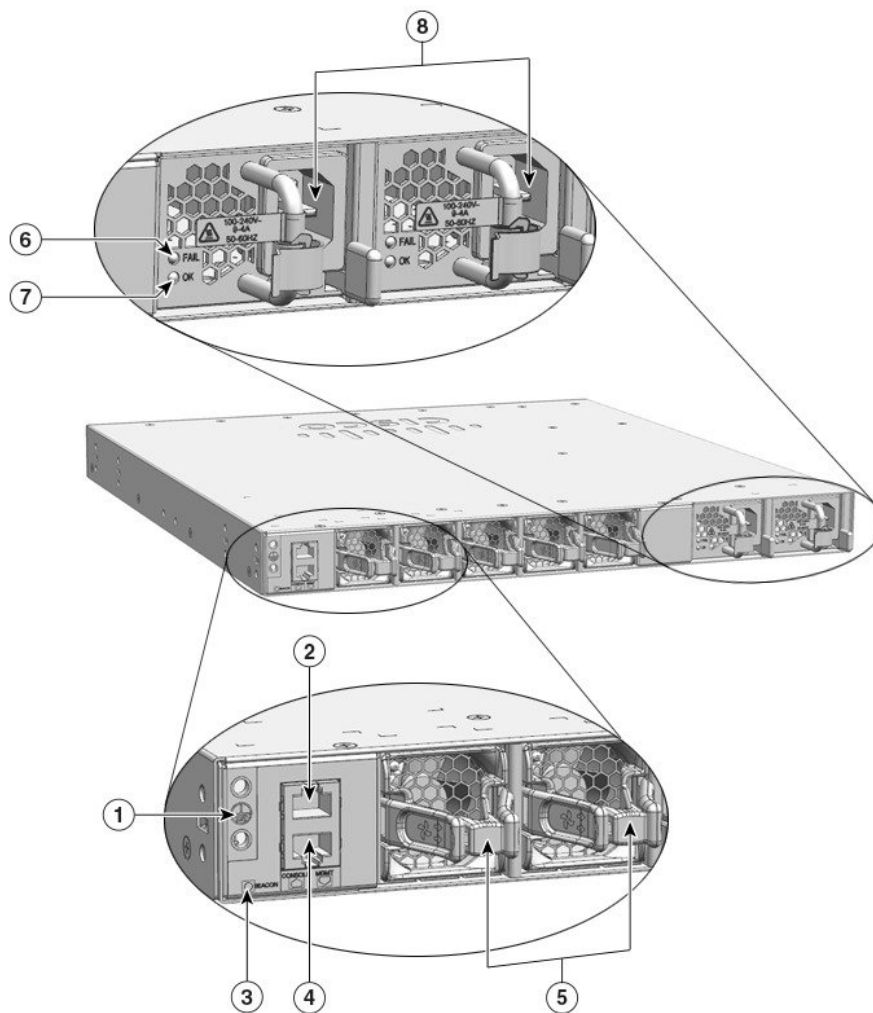
Figure 12: WS-C3850-12S and WS-C3850-24S Switches Switch Rear Panel



1	Ground connector	7	StackWise port connector
2	CONSOLE (RJ-45 console port)	8	StackPower connector

3	MGMT (RJ-45 10/100/1000 management port)	9	AC OK (input) status LED
4	RESET button	10	PS OK (output) status LED
5	BEACON LED	11	Power supply modules (AC power supply modules shown)
6	Fan module		

Figure 13: WS-C3850-48XS Switches Switch Rear Panel



354194

1	Ground connector	5	Fan module
---	------------------	---	------------

2	CONSOLE (RJ-45 console port)	6	Power supply FAIL LED
3	BEACON LED	7	Power supply OK LED
4	MGMT (RJ-45 10/100/1000 management 9 AC OK (input) status LED port)	8	Power supply modules

## RJ-45 Console Port LED

Table 12: RJ-45 Console Port LED

Color	RJ-45 Console Port Status
Off	RJ-45 console is disabled. USB console is active.
Green	RJ-45 console is enabled. USB console is disabled.

## StackWise Ports

StackWise ports are used to connect switches in StackWise stacking configurations. The switch ships with a 0.5-meter StackWise cable that you can use to connect the StackWise ports. For more information on StackWise cables, see [Connecting to the StackWise Ports, on page 47](#).



**Note** The following switch models do not support StackWise-480:

- WS-C3850-48XS-S
- WS-C3850-48XS-E
- WS-C3850-48XS-F-S
- WS-C3850-48XS-F-E



**Caution** Use only approved cables, and connect only to similar Cisco equipment. Equipment might be damaged if connected to nonapproved Cisco cables or equipment.

## Power Supply Modules

The switches are powered through one or two internal power supply modules.

Supported power supply modules:

- PWR-C1-350WAC

- PWR-C1-715WAC
- PWR-C1-1100WAC
- PWR-C1-440WDC

The following power supply modules are applicable to only the WS-C3850-48XS switches:

- PWR-C3-750WAC-R: This module has red handles to match fans with red handles. Airflow is from the front panel to the rear panel (warm air is ‘pulled out of’ the switch.)
- PWR-C3-750WAC-F: This module has blue handles to match fans with blue handles. Airflow is from the rear panel to the front panel (cool air is ‘pushed into’ the switch.)
- PWR-C3-750WDC-R: This module has red handles to match fans with red handles. Airflow is from the front panel to the rear panel (warm air is ‘pulled out of’ the switch.)
- PWR-C3-750WDC-F: This module has blue handles to match fans with blue handles. Airflow is from the rear panel to the front panel (cool air is ‘pushed into’ the switch.)

The switch has two internal power supply module slots. You can use two AC modules, two DC modules, a mixed configuration of one AC and one DC power supply module, or one power supply module and a blank module.

The switch can operate with either one or two active power supply modules or with power supplied by a stack. A Catalyst 3850 switch that is in a StackPower stack can operate with power supplied by other switches in the stack.

[Switch Models, on page 1](#) shows the default power supply modules that ship with each switch model. All power supply modules (except the blank modules) have internal fans. All switches ship with a blank power supply module in the second power supply slot.


**Caution**

Do not operate the switch with one power supply module slot empty. For proper chassis cooling, both power supply module slots must be populated with either a power supply or a blank module.

The 350-W and 715-W AC power supply modules are autoranging units that support input voltages between 100 and 240 VAC. The 1100-W power supply module is an autoranging unit that supports input voltages between 115 and 240 VAC. The 440-W DC power supply module has dual input feeds (A and B) and supports input voltages between 36 and 72 VDC. The output voltage range is 51 to 57 V.

Each AC power supply module has a power cord for connection to an AC power outlet. The 1100-W and 715-W modules use a 16-AWG cord (only North America). All other modules use an 18-AWG cord. The DC-power supply module must be wired to a DC-power source.

The following tables show the PoE available and PoE requirements for Catalyst 3850 PoE switch models.

**Table 13: Available PoE with AC Power Supply**

Models	Default Power Supply	Available PoE
12-port data switch	PWR-C1-350WAC	—
24-port data switch		
48-port data switch		

Models	Default Power Supply	Available PoE
24-port PoE+ switch	PWR-C1-715WAC	435 W
48-port PoE+ switch		
48-port full PoE+ switch	PWR-C1-1100WAC	800 W
24-port Cisco UPOE switch		
48-port Cisco UPOE switch		

**Table 14: Available PoE with DC Power Supply**

Models	Number of Power Supplies	Available PoE
24-port PoE+ switch	1	220 W
	2	660 W
48-port PoE+ switch	1	185 W
	2	625 W
24-port Cisco UPOE switch	1	220 W
	2	660 W
48-port Cisco UPOE switch	1	185 W
	2	625 W

**Table 15: Switch Power Supply Requirements for PoE, PoE+, and Cisco UPoE**

PoE Option	24-Port Switch	48-Port Switch <sup>11</sup>
PoE (up to 15.4 per port)	(1) 715 W	These are the combinations of power supplies: <ul style="list-style-type: none"> <li>• (1) 1100 W</li> <li>• (1) 715 W + (1) 715 W</li> </ul>
PoE+ (up to 30 W per ports)	These are the combinations of power supplies: <ul style="list-style-type: none"> <li>• (1) 1100 W</li> <li>• (1) 715 W + (1) 715 W</li> </ul>	These are the combinations of power supplies: <ul style="list-style-type: none"> <li>• (1) 1100 W + (1) 715 W</li> <li>• (2) 1100 W</li> </ul>

PoE Option	24-Port Switch	48-Port Switch <sup>11</sup>
Cisco UPoE (up to 60 W per port)	(2) 1100 W	These are the combinations of power supplies: <ul style="list-style-type: none"> <li>• (1) 1100 W + (1) 715 W</li> <li>• (2) 1100 W</li> </ul> <b>Note</b> Up to 30 PoE ports can receive full Cisco UPoE.

<sup>11</sup> A 48-port switch with one 715-W power supply provides up to 8.7 W of PoE to all ports.



- Note** Considerations for the WS-C3850-12X48U-L, WS-C3850-12X48U-S and WS-C3850-12X48U-E switch models:
- The primary power supply for these switch models should be a minimum of 470 W.
  - 350 W or 440 W can be used only as secondary power supplies. If the switch draws power from these modules as the primary source, reboot the switch to restore these modules as secondary power supplies.

The power supply modules have two status LEDs.

**Table 16: Switch Power Supply Module LEDs**

AC OK	Description	PS OK	Description
DC OK			
Off	No AC input power. No DC input power.	Off	Output is disabled, or input is outside operating range (AC LED is off). Output is disabled, or input is outside operating range (DC LED is off).
Green	AC input power present. DC input power present.	Green	Power output to switch active.
		Red	Output has failed.

For information about replacing a power supply module, wiring a DC power supply module, and module specifications, see the "Power Supply Installation" and "Technical Specifications" chapters.

## Fan Module

Depending on the switch model, three or five internal hot-swappable 12-V fan modules (FAN-T1=) are available. The air circulation system consists of the fan modules and the power supply modules. The airflow patterns vary depending on the power supply configuration.

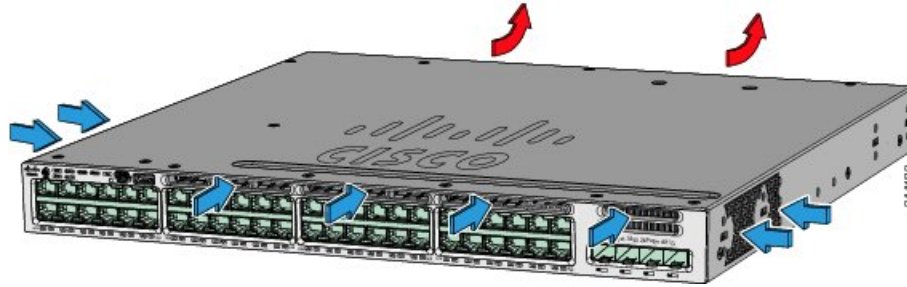
When the fan modules are operating properly, a green LED is on at the top left corner of the fan assembly (viewed from the rear). If the fan fails, the LED turns to amber. The switch can operate with two operational fans, but the failed fan should be replaced as soon as possible to avoid a service interruption due to a second fan fault.



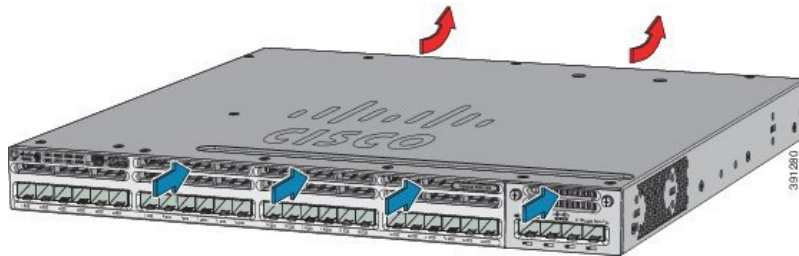
**Note** The WS-C3850 switches require three fans for proper cooling. The WS-C3850-48XS switches require five fans for proper cooling.

**Figure 14: 24- and 48-Port Switch Airflow Patterns**

The following illustrations show the airflow patterns for the 24- and 48-port switches. The blue arrow shows cool airflow, and the red arrow shows warm airflow.



**Figure 15: Airflow Patterns for the Catalyst 3850-24S-E and 3850-12S-E Switches**



**Figure 16: Airflow Patterns for the Catalyst 3850-48XS Switches (using Power Supplies and Fans with Blue Handles)**

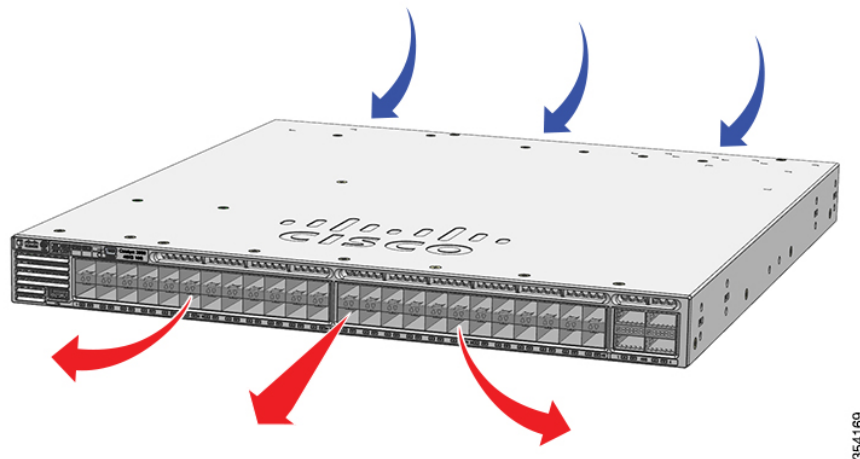
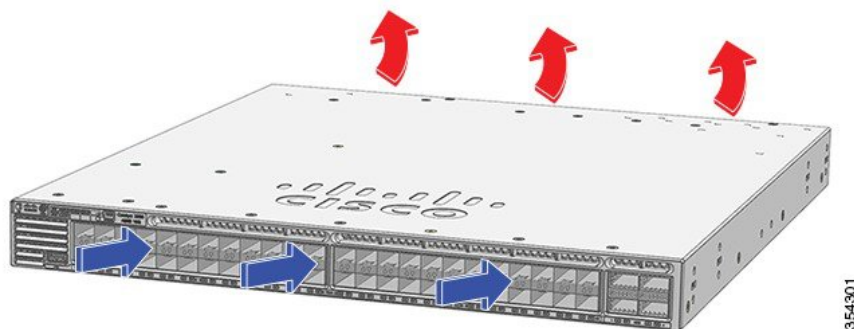


Figure 17: Airflow Patterns for the Catalyst 3850-48XS Switches (using Power Supplies and Fans with Red Handles)



For information about installing a fan module and fan specifications, see the "Technical Specifications" chapter.

## StackPower Connector

The switches have a StackPower connector for use with Cisco StackPower cables to configure a switch power stack that includes up to nine switches. A switch power stack can be configured in redundant or power-sharing mode.

You can order these StackPower cables from your Cisco sales representative:

- CAB-SPWR-30CM (0.3-meter cable)
- CAB-SPWR-150CM (1.5-meter cable)

For details about connecting StackPower cables and StackPower guidelines, see [Planning a StackPower Stack, on page 40](#).




---

**Note** Cisco Catalyst WS-C3850-48XS switch models do not have the StackPower connector.

---

## Ethernet Management Port

You can connect the switch to a host such as a Windows workstation or a terminal server through the 10/100/1000 Ethernet management port or one of the console ports. The 10/100/1000 Ethernet management port is a VPN routing/forwarding (VRF) interface and uses a RJ-45 crossover or straight-through cable.




---

**Note** The 10/100/1000 Ethernet management port is an RJ-45 connector that should be connected to a Windows workstation or a terminal server. Do not connect this port to another port in the same switch or to any port within the same switch stack.

---

The following table shows the Ethernet management port LED colors and their meanings.

**Table 17: Ethernet Management Port LED**

Color	Description
Green	Link up but no activity.
Blinking green	Link up and activity.
Off	Link down.

## RJ-45 Console Port

The RJ-45 console port connection uses the supplied RJ-45-to-DB-9 female cable.

The following table shows the RJ-45 console port LED colors and their meanings.

**Table 18: RJ-45 Console LED**

Color	Description
Green	RJ-45 console port is active.
Off	The port is not active.

## Management Options

- Cisco Network Assistant

Cisco Network Assistant is a PC-based network management GUI application for LANs. You can use the GUI to configure and manage switch clusters or standalone switches. Cisco Network Assistant is available at no cost and can be downloaded from this URL: <http://www.cisco.com/pcgi-bin/tablebuild.pl/NetworkAssistant>

- Cisco IOS CLI

You can configure and monitor the switch and switch cluster members from the CLI. You can access the CLI by connecting your management station directly to the switch console port or by using Telnet from a remote management station. See the switch command reference on Cisco.com for more information.

- Cisco Prime Infrastructure

Cisco Prime Infrastructure combines the wireless functionality of Cisco Prime Network Control System (NCS) and the wired functionality of Cisco Prime LAN Management Solution (LMS), with application performance monitoring and troubleshooting capabilities of Cisco Prime Assurance Manager. For more information, see the Cisco Prime Infrastructure documentation on Cisco.com: <http://www.cisco.com/en/US/products/ps12239/index.html>





## CHAPTER 2

# Switch Installation

---

For initial switch setup, assigning the switch IP address, and powering on information, see the switch getting started guide on Cisco.com.

This chapter contains these topics:

- [Preparing for Installation, on page 33](#)
- [Planning a Switch Data Stack, on page 36](#)
- [Data Stack Cabling Configurations, on page 38](#)
- [Planning a StackPower Stack, on page 40](#)
- [StackPower Cabling Configurations, on page 41](#)
- [Installing the Switch, on page 43](#)
- [Connecting to the StackWise Ports, on page 47](#)
- [Connecting to the StackPower Ports, on page 48](#)
- [Installing a Network Module in the Switch, on page 49](#)
- [Installing and Removing SFP, SFP+ and QSFP+ Modules, on page 49](#)
- [Connecting Devices to the Ethernet Ports, on page 49](#)
- [Where to Go Next, on page 51](#)

## Preparing for Installation

### Safety Warnings

This section includes the basic installation caution and warning statements. Read this section before you start the installation procedure. Translations of the warning statements appear in the Regulatory Compliance and Safety Information guide on Cisco.com.



---

**Warning**

Before working on equipment that is connected to power lines, remove jewelry (including rings, necklaces, and watches). Metal objects will heat up when connected to power and ground and can cause serious burns or weld the metal object to the terminals. Statement 43

---



**Warning** Do not stack the chassis on any other equipment. If the chassis falls, it can cause severe bodily injury and equipment damage. Statement 48



**Warning** Ethernet cables must be shielded when used in a central office environment. Statement 171



**Warning** Do not work on the system or connect or disconnect cables during periods of lightning activity. Statement 1001



**Warning** Read the installation instructions before connecting the system to the power source. Statement 1004



**Warning** Class 1 laser product. Statement 1008



**Warning** This unit is intended for installation in restricted access areas. A restricted access area can be accessed only through the use of a special tool, lock and key, or other means of security. Statement 1017



**Warning** The plug-socket combination must be accessible at all times, because it serves as the main disconnecting device. Statement 1019



**Warning** Use copper conductors only. Statement 1025



**Warning** This unit might have more than one power supply connection. All connections must be removed to de-energize the unit. Statement 1028



**Warning** Only trained and qualified personnel should be allowed to install, replace, or service this equipment. Statement 1030



**Warning** Ultimate disposal of this product should be handled according to all national laws and regulations. Statement 1040



---

**Warning** To prevent the system from overheating, do not operate it in an area that exceeds the maximum recommended ambient temperature of: <113°F (45°C). Statement 1047

---



---

**Warning** Installation of the equipment must comply with local and national electrical codes. Statement 1074

---



---

**Warning** To prevent airflow restriction, allow clearance around the ventilation openings to be at least: 3 inches (7.6 cm). Statement 1076

---



---

**Note** The grounding architecture of this product is DC-isolated (DC-I).

---

## Installation Guidelines

When determining where to install the switch, verify that these guidelines are met:

- Clearance to the switch front and rear panel meets these conditions:
  - Front-panel LEDs can be easily read.
  - Access to ports is sufficient for unrestricted cabling.
  - AC power cord can reach from the AC power outlet to the connector on the switch rear panel.
  - The SFP/SFP+ module minimum bend radius and connector length is met. See the SFP/SFP+ module documentation for more information.
- Cabling is away from sources of electrical noise, such as radios, power lines, and fluorescent lighting fixtures. Make sure that the cabling is safely away from other devices that might damage the cables.
- For switches with the optional 1100-W power-supply module (PWR-C1-1100WAC=), first rack-mount the switch before installing the power-supply module.
- Make sure power-supply modules and fan modules are securely inserted in the chassis before moving the switch.
- When connecting or disconnecting the power cord on a switch that is installed above or below a 1100-W power supply-equipped switch, you might need to remove the module from the switch to access the power cord.
- Airflow around the switch and through the vents is unrestricted.
- For copper connections on Ethernet ports, cable lengths from the switch to connected devices can be up to 328 feet (100 meters).
- Temperature around the unit does not exceed 113°F (45°C). If the switch is installed in a closed or multirack assembly, the temperature around it might be greater than normal room temperature.

- Humidity around the switch does not exceed 95 percent.
- Altitude at the installation site is not greater than 10,000 feet.
- Cooling mechanisms, such as fans and blowers in the switch, can draw dust and other particles causing contaminant buildup inside the chassis, which can result in system malfunction. You must install this equipment in an environment as free from dust and foreign conductive material (such as metal flakes from construction activities) as is possible.

## Box Contents

The switch getting started guide describes the box contents. If any item is missing or damaged, contact your Cisco representative or reseller for support.

## Tools and Equipment

Obtain these necessary tools:

- A Number-2 Phillips screwdriver to rack-mount the switch

## Verifying Switch Operation

Before you install the switch in a rack, or on a table or shelf, you should power on the switch and verify that the switch passes POST. See the “Running Express Setup” section in the getting started guide for the steps required to connect a PC to the switch and to run Express Setup.

## Powering Off the Switch

After a successful POST, disconnect the power cord from the switch. Install the switch in a rack, on a table, or on a shelf as described in [Installing the Switch, on page 43](#).

## Planning a Switch Data Stack

Catalyst 3850 switches can share bandwidth by using data stacking.



---

**Note** The following switch models do not support StackWise-480:

- WS-C3850-48XS-S
  - WS-C3850-48XS-E
  - WS-C3850-48XS-F-S
  - WS-C3850-48XS-F-E
-

## Switch Stacking and Power Stacking Guidelines

Before connecting the switches in a stack, keep in mind these stacking guidelines:

- Size of the switch and any optional power-supply module. The 1100-W power-supply module is longer than the other modules. Stacking switches with the same power-supply modules together makes it easier to cable the switches.
- Length of cable. Depending on the configurations that you have, you might need different-sized cables. If you do not specify the length of the StackWise cable, the 0.5-meter cable is supplied. If you need the 1-meter cable or the 3-meter cable, you can order it from your Cisco supplier. For cable part numbers, see [StackWise Ports, on page 25](#). The [Data Stack Cabling Configurations, on page 38](#) provides examples of recommended configurations.
- For rack-mounted switch stacks that are members of a StackPower stack as well as a data stack, see [Planning a StackPower Stack, on page 40](#).
- You can create data stacks with up to nine switches in a stack.



---

**Note** Special considerations for the following switch models:

- WS-C3850-24XS-E
- WS-C3850-24XS-S
- WS-C3850-24XU-E
- WS-C3850-24XU-L
- WS-C3850-24XU-S
- WS-C3850-12X48U-L
- WS-C3850-12X48U-S
- WS-C3850-12X48U-E

Information:

- If you set up a stack with these switches, the stack can have a maximum of 8 switches only. Each of the above switch models have 4 ASIC chips, and the maximum number of ASIC chips per stack cannot exceed 32.
- If you set up a stack that contains the above switches and other Catalyst 3850 switches, ensure that the maximum number of ASIC chips is 32.



---

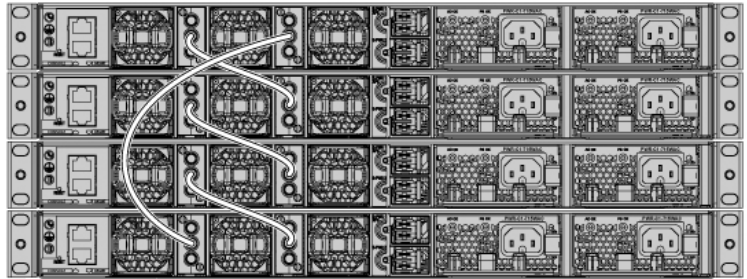
**Note** The Catalyst WS-C3850-48XS switch models do not support power stacking.

---

## Data Stack Cabling Configurations

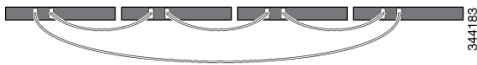
This is an example of a recommended configuration that uses the supplied 0.5-meter StackWise cable. In this example, the switches are stacked in a vertical rack or on a table. This configuration provides redundant connections. The configuration example uses the supplied 0.5-meter StackWise cable. The example shows the full-ring configuration that provides redundant connections.

**Figure 18: Data Stacking the Switches in a Rack or on a Table Using the 0.5-meter StackWise Cables**



This example shows a recommended configuration when the switches are mounted side-by-side. Use the 1-meter and the 3-meter StackWise cables to connect the switches. This configuration provides redundant connections.

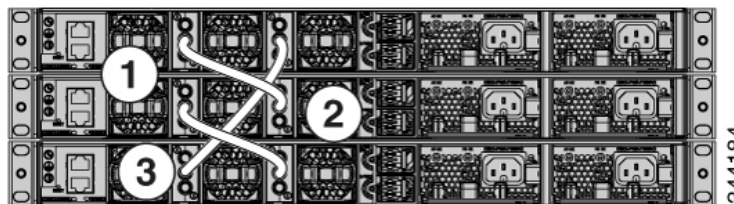
**Figure 19: Data Stacking in a Side-by-Side Mounting**



## Data Stack Bandwidth and Partitioning Examples

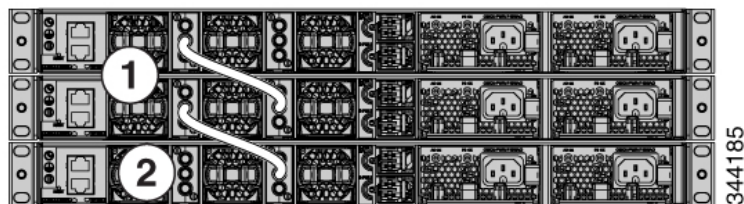
This section provides examples of data stack bandwidth and possible data stack partitioning. The figure shows a data stack of switches that provides full bandwidth and redundant StackWise cable connections.

**Figure 20: Example of a Data Stack with Full Bandwidth Connections**



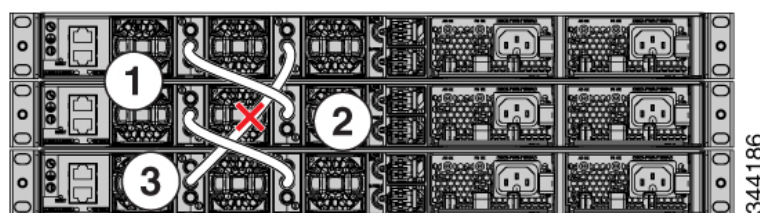
This figure shows an example of a stack of switches with incomplete StackWise cabling connections. This stack provides only half bandwidth and does not have redundant connections.

**Figure 21: Example of a Data Stack with Half Bandwidth Connections**



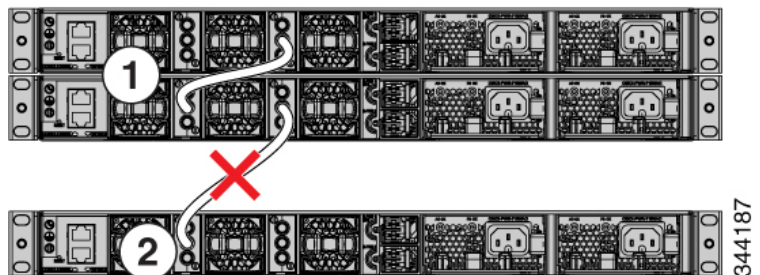
The figures below show data stacks of switches with failover conditions. In this figure, the StackWise cable is bad in link 2. Therefore, this stack provides only half bandwidth and does not have redundant connections.

**Figure 22: Example of a Data Stack with a Failover Condition**



In this figure, link 2 is bad. Therefore, this stack partitions into two stacks, and the top and bottom switches become the active switch in the stack. If the bottom switch is a member (not active or standby switch), it reloads.

**Figure 23: Example of a Partitioned Data Stack with a Failover Condition**



## Power-On Sequence for Switch Stacks

Consider these guidelines before you power on the switches in a stack:

- The sequence in which the switches are first powered on might affect the switch that becomes the stack master.
- There are two ways to elect an active switch:
  - If you want a particular switch to become the active switch, configure it with the highest priority. Among switches with same priority, the switch with the lowest MAC address becomes the active switch.
  - If you want a particular switch to become the active switch, power on that switch first. This switch remains the active switch until a reelection is required. After 2 minutes, power on the other switches in the stack. If you have no preference as to which switch becomes the active switch, power on all

the switches in the stack within 1 minute. These switches participate in the active switch election. Switches powered on after 2 minutes do not participate in the election.

If changes are made to the stack without powering down the switches, the following results can occur:

- If two operating partial ring stacks are connected together using a stack cable, a stack merge can take place. This situation reloads the whole stack (all switches in the stack).
- If some switches in the stack are completely separated from the stack, a stack split can occur.
- A stack split can occur on a full ring stack if:
  - More than one running switch is removed without powering down.
  - More than one stack cable is removed without powering down.
- A stack split can occur in a partial ring stack if:
  - A switch is removed without powering down.
  - A stack cable is removed without powering down.
- In a split stack, depending on where the active and standby switches are located, either two stacks might be formed (with the standby taking over as the new active switch in the newly formed stack) or all the members in the newly formed stack might reload.



---

**Note** These results depend on how the switches are connected. You can remove two or more switches from the stack without splitting the stack.

---

For conditions that can cause a stack reelection or to manually elect the active switch, see the stacking software configuration guide on Cisco.com at this URL: <http://www.cisco.com/c/en/us/support/switches/catalyst-3850-series-switches/products-installation-and-configuration-guides-list.html>.

## Planning a StackPower Stack

### StackPower Stacking Guidelines

You can configure a StackPower stack for either power sharing or redundancy. In power-sharing mode, the power of all the power supplies in the stack is aggregated and distributed among the stack members.

In redundant mode, when the total power budget of the stack is calculated, the wattage of the largest power supply is not included. That power is held in reserve and used to maintain power to switches and attached devices when one power supply fails. Following the failure of a power supply, the StackPower mode becomes power sharing.



---

**Note** Power-sharing mode is the recommended configuration for Cisco Catalyst 3850 Series Switches .

---

For general concepts and management procedures for switch power stacks, see the Software Configuration Guide on Cisco.com.

Before connecting the switches in a power stack, keep in mind these guidelines:

- A switch power stack can include a maximum of four switches in a ring topology and nine switches in a star topology.
- Size of the switch and any optional power supply module. The 1100-W power-supply module is 1.5 inches (3.81 cm) longer than the other modules, and with the attached cable retention clip, it extends 3 inches (7.62 cm) from the switch chassis. Stacking switches with the same power-supply modules together makes it easier to cable the switches. For switch dimensions, see Appendix A, “Technical Specifications.”
- Length of cable. Depending on the configurations that you have, you might need different-sized cables. If you do not specify the length of the StackPower cable, the 0.3 meter cable is supplied. If you need the 1.5 meter cable, you can order it from your Cisco supplier. For cable part numbers, see [StackPower Connector, on page 30](#). The [StackPower Cabling Configurations, on page 41](#) provides examples of recommended configurations.
- For rack-mounted switch stacks that are members of a data stack and a StackPower stack, see [Switch Stacking and Power Stacking Guidelines, on page 37](#)

## StackPower Cabling Configurations

This section describes the recommended cabling configurations for a StackPower stack. There are two types of StackPower cables.

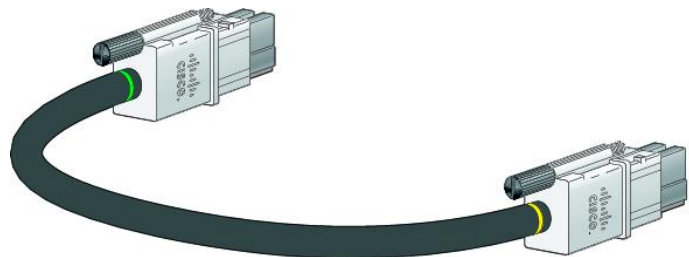
The cable in the figure connects a switch to another switch in a power stack or with an XPS. StackPower cables have color bands on the cable ends:

- The cable end with the green band can connect only to a switch.
- The cable end with the yellow band can connect to a switch or an XPS.

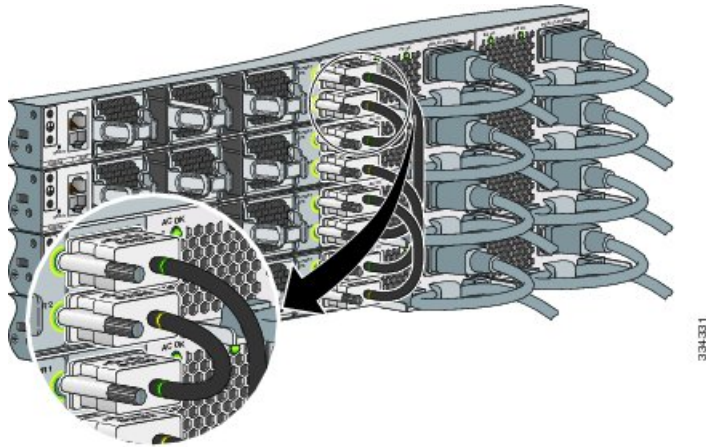
The cable is available in two lengths.

Part Number	Cable Type	Length
CAB-SPWR-30CM	StackPower Cable	0.3 meter
CAB-SPWR-150CM	StackPower Cable	1.5 meter

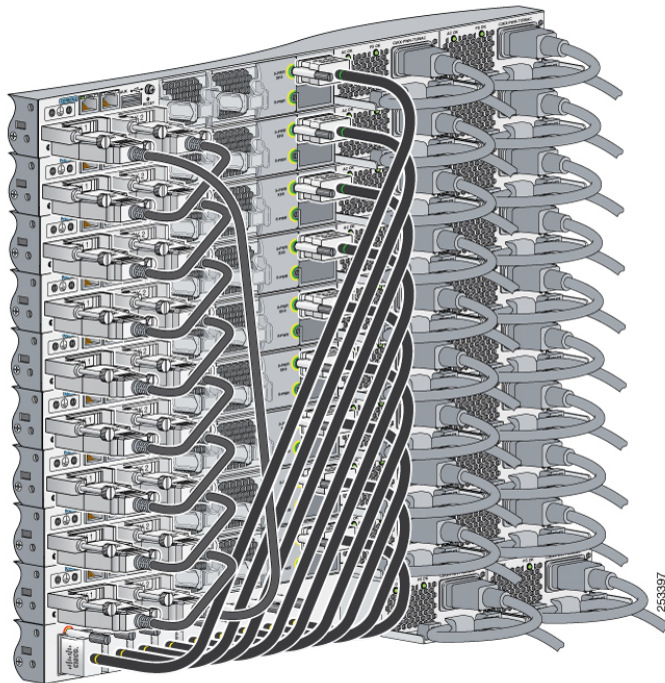
**Figure 24: StackPower Cable for Use with Cisco Catalyst 3850 Series Switches**



This figure shows a ring configuration using both of the supplied 0.3-meter StackPower cables and one 1.5-meter cable. In the examples that follow, the switches are stacked in a vertical rack or on a table.

*Figure 25: StackPower Ring Topology*

This figure shows 9 switches connected in a star topology.

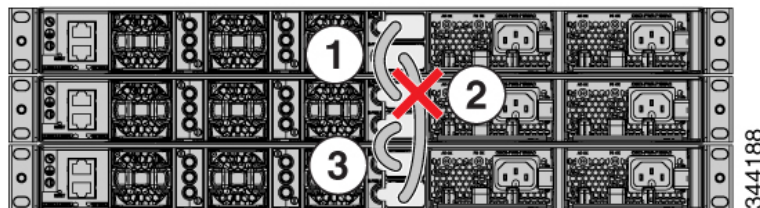
*Figure 26: StackPower Star Topology*

## StackPower Partitioning Examples

These figures show StackPower stacks of switches with failover conditions.

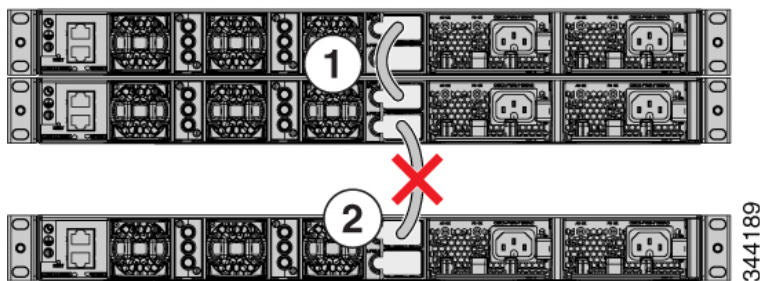
In this figure, the StackPower cable 2 is faulty. Therefore, this stack does not provide redundancy.

Figure 27: Example of a StackPower Stack with a Failover Condition



In this figure, StackPower port B on the center switch has failed and this stack partitions into two stacks. The top two switches share power, and the bottom switch is now a separate stack.

Figure 28: Example of a Partitioned StackPower Stack with a Failover Condition



## Installing the Switch

### Rack-Mounting

Installation in racks other than 19-inch racks requires a bracket kit not included with the switch.



#### Warning

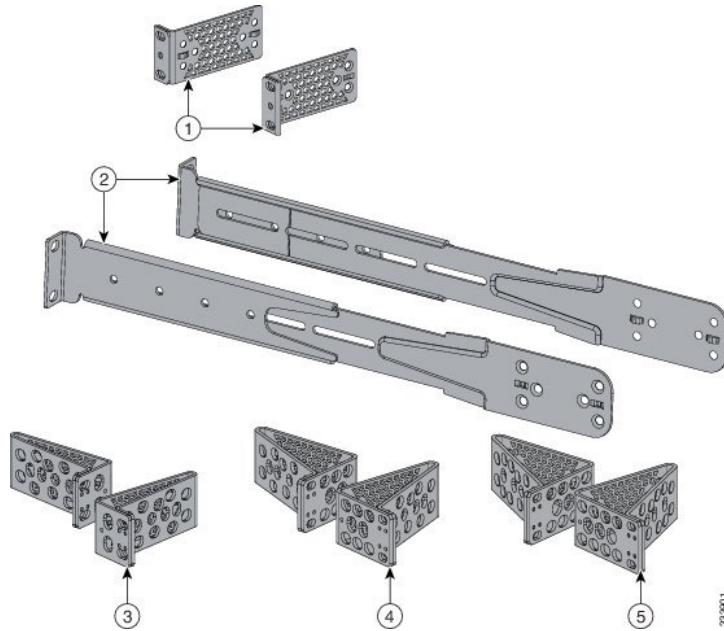
To prevent bodily injury when mounting or servicing this unit in a rack, you must take special precautions to ensure that the system remains stable. The following guidelines are provided to ensure your safety:

- This unit should be mounted at the bottom of the rack if it is the only unit in the rack.
- When mounting this unit in a partially filled rack, load the rack from the bottom to the top with the heaviest component at the bottom of the rack.
- If the rack is provided with stabilizing devices, install the stabilizers before mounting or servicing the unit in the rack.

Statement 1006

**Figure 29: Rack-Mounting Brackets**

This figure shows the standard 19-inch brackets and other optional mounting brackets. You can order the optional brackets from your Cisco sales representative.



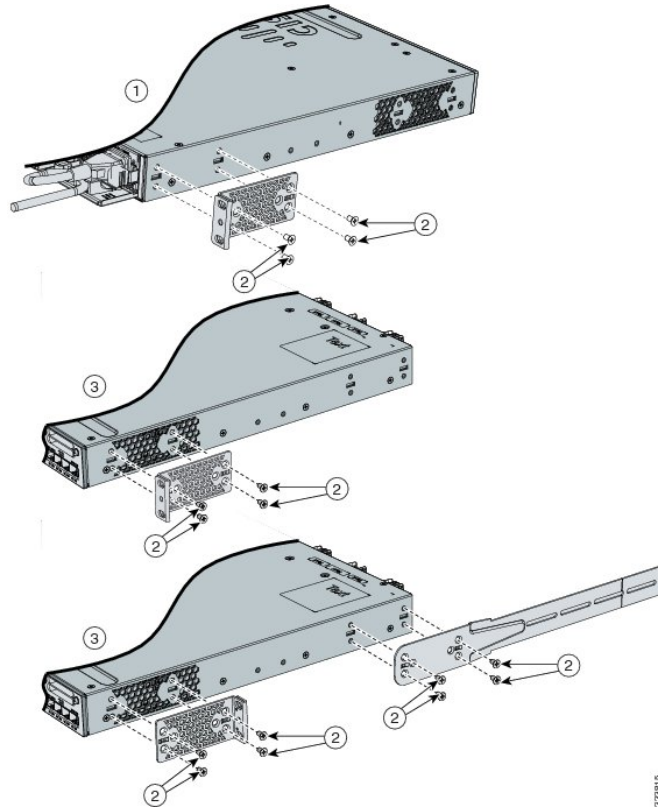
1	19-inch brackets (C3850-RACK-KIT=)	4	23-inch brackets (C3850-RACK-KIT=)
2	Extension rails and brackets for four-point mounting, includes 19-inch brackets. (C3850-4PT-KIT=)	5	24-inch brackets (C3850-RACK-KIT=)
3	ETSI brackets (C3850-RACK-KIT=)		

## Attaching the Rack-Mount Brackets

### Procedure

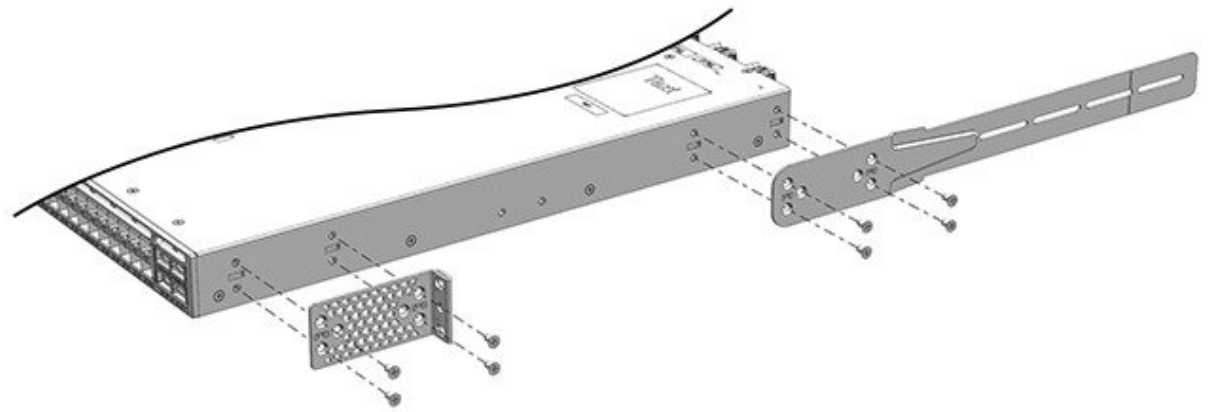
Use four Phillips flat-head screws to attach the long side of the bracket to each side of the switch for the front- or rear-mounting positions.

Figure 30: Attaching Brackets for 19-inch Racks



1	Rear-mounting position	3	Front-mounting position
2	Number-8 Phillips flat-head screws		

Figure 31: Attaching Brackets for Catalyst WS-C3850-48XS Switches

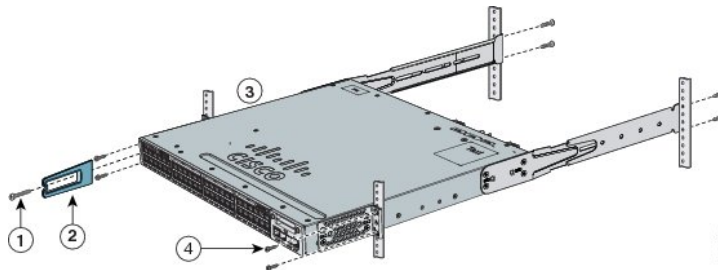


354193

## Mounting the Switch a Rack

### Procedure

- Step 1** Use the four supplied Phillips machine screws to attach the brackets to the rack.
- Step 2** Use the black Phillips machine screw to attach the cable guide to the left or right bracket.



1	Phillips machine screw, black	4	Front-mounting position
2	Cable guide	5	Number-12 or number-10 Phillips machine screws

## Installing the Switch on a Table or Shelf

### Procedure

---

- Step 1** To install the switch on a table or shelf, locate the adhesive strip with the rubber feet in the mounting-kit envelope.
- Step 2** Attach the four rubber feet to the four circular etches on the bottom of the chassis.
- Step 3** Place the switch on the table or shelf near an AC power source.
- Step 4** When you complete the switch installation, see [After Switch Installation, on page 47](#) for information on switch configuration.
- 

## After Switch Installation

- Configure the switch by running Express Setup to enter the initial switch configuration. See the switch getting started guide on Cisco.com.
- Use the CLI setup program to enter the initial switch configuration.
- Connect to the front-panel ports.

## Connecting to the StackWise Ports

### Before you begin

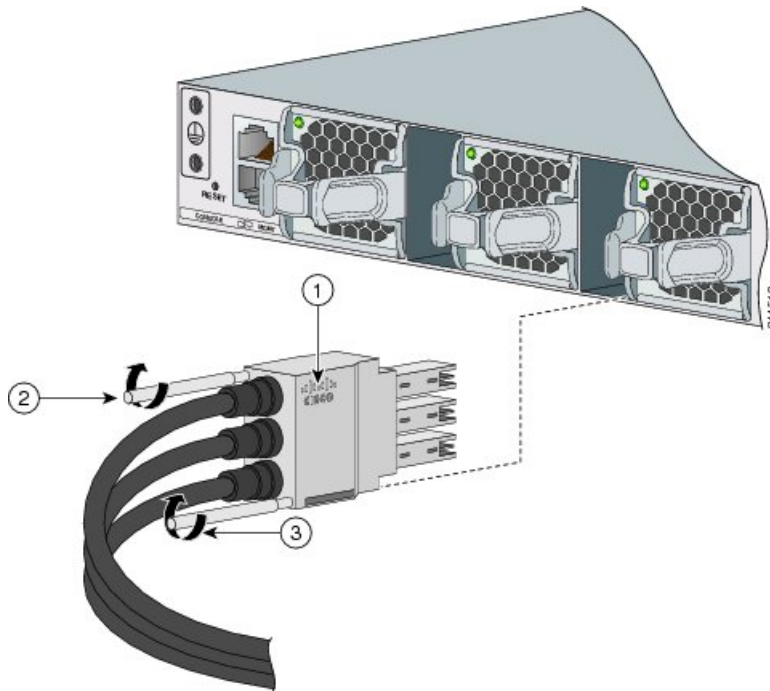
Before connecting the StackWise cables, review the [Planning a Switch Data Stack, on page 36](#). Always use a Cisco-approved StackWise cable to connect the switches.

### Procedure

---

- Step 1** Remove the dust covers from the StackWise cables and StackWise ports, and store them for future use.
- Step 2** Connect the cable to the StackWise port on the switch rear panel. Align the connector and connect the StackWise cable to the StackWise port on the switch rear panel and finger-tighten the screws (clockwise direction). Make sure the Cisco logo is on the top side of the connector as shown in the figure.
- Step 3** Connect the other end of the cable to the port on the other switch and finger-tighten the screws. Avoid overtightening the screws.

Figure 32: Connecting the StackWise Cable in a StackWise Port



1	Cisco logo	3	Connector screw
2	Connector screw		

**Caution** Removing and installing the StackWise cable can shorten its useful life. Do not remove and insert the cable more often than is absolutely necessary (installing and removing it up to 200 times is supported).

When you need to remove the StackWise cable from the connector, make sure to fully unscrew the correct screws. When the connectors are not being used, replace the dust covers.

## Connecting to the StackPower Ports

### Before you begin

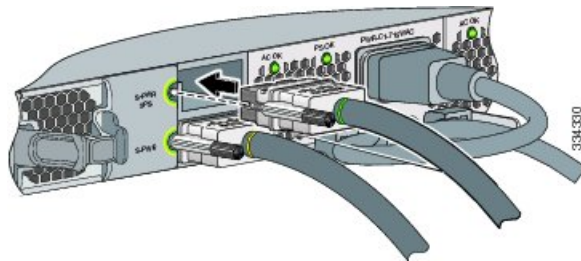
Before connecting the StackPower cables, review [Planning a Switch Data Stack, on page 36](#). Always use a Cisco-approved StackWise cable to connect the switches. To prevent misconfiguration, the StackPower ports on the switch are keyed and have colored bands that match the keying and bands on the StackPower cable connectors.

### Procedure

- Step 1** Remove the dust covers from the StackPower cable connectors.

- Step 2** Connect the end of the cable with a green band to either StackPower port on the first switch. Align the connector correctly, and insert it into a StackPower port on the switch rear panel.
- Step 3** Connect the end of the cable with the yellow band to another switch (to configure StackPower power sharing).
- Step 4** Hand-tighten the captive screws to secure the StackPower cable connectors in place.

*Figure 33: Connecting the StackPower Cable to a StackPower Port*



**Caution** Removing and installing the StackPower cable can shorten its useful life. Do not remove and insert the cable more often than is absolutely necessary.

## Installing a Network Module in the Switch

See these sections for information on network modules:

- [Installing Network Modules, on page 59](#)

## Installing and Removing SFP, SFP+ and QSFP+ Modules

See these sections for information on SFP, SFP and QSFP+ modules:

- [Installing SFP and SFP+ Modules, on page 65](#)
- [Removing SFP and SFP+ Modules, on page 66](#)
- [Cisco 40-Gigabit QSFP+ Transceiver Modules Installation Note](#)

## Connecting Devices to the Ethernet Ports

- [10/100/1000 Port Connections, on page 49](#)
- [PoE+ and Cisco UPOE Port Connections, on page 50](#)

### 10/100/1000 Port Connections

The switch 10/100/1000 port configuration changes to operate at the speed of the attached device. If the attached ports do not support autonegotiation, you can manually set the speed and duplex parameters.

Connecting devices that do not autonegotiate or that have the speed and duplex parameters manually set can reduce performance or result in no linkage.

To maximize performance, choose one of these methods for configuring the Ethernet ports:

- Let the ports autonegotiate both speed and duplex.
- Set the interface speed and duplex parameters on both ends of the connection.

## Auto-MDIX Connections

The autonegotiation and the auto-MDIX features are enabled by default on the switch.

With autonegotiation, the switch port configurations change to operate at the speed of the attached device. If the attached device does not support autonegotiation, you can manually set the switch interface speed and duplex parameters.

With auto-MDIX, the switch detects the required cable type for copper Ethernet connections and configures the interface accordingly.

If auto-MDIX is disabled, use the guidelines in this table to select the correct cable.

**Table 19: Recommended Ethernet Cables (When Auto-MDIX is Disabled)**

Device	Crossover Cable	Straight-Through Cable
Switch to switch	Yes	No
Switch to hub	Yes	No
Switch to computer or server	No	Yes
Switch to router	No	Yes
Switch to IP phone	No	Yes

<sup>12</sup> 100BASE-TX and 1000BASE-T traffic requires twisted four-pair, Category 5 or higher. 10BASE-T traffic can use Category 3 cable or higher.

## PoE+ and Cisco UPOE Port Connections

The 10/100/1000 PoE+ and Cisco UPOE ports have the same autonegotiation settings and cabling requirements that are described in the [10/100/1000 Port Connections](#), on page 49. These ports can provide PoE, PoE+, or Cisco UPOE inline power.



**Note** Be careful when connecting a “snagless” Ethernet cable to port 1 on a 48-port switch. The protective boot of the cable might inadvertently press the Mode button, which might cause the switch to erase its startup configuration and reboot. See this field notice for more information: <http://www.cisco.com/c/en/us/support/docs/field-notices/636/fn63697.html>

This issue does not occur if you are using Cisco IOS XE Release 3E or later releases.

PoE inline power supports devices compliant with the IEEE 802.3af standard, as well as prestandard Cisco IP Phones and Cisco Aironet Access Points. Each port can deliver up to 15.4 W of PoE. PoE+ inline power supports devices compliant with the IEEE 802.3at standard, by delivering up to 30 W of PoE+ power per port to all switch ports.

See [Power Supply Modules](#) for the power supply modules required to support PoE, PoE+, and Cisco UPOE on 24- and 48-port switches.

**Warning**

Voltages that present a shock hazard may exist on Power over Ethernet (PoE) circuits if interconnections are made using uninsulated exposed metal contacts, conductors, or terminals. Avoid using such interconnection methods, unless the exposed metal parts are located within a restricted access location and users and service people who are authorized within the restricted access location are made aware of the hazard. A restricted access area can be accessed only through the use of a special tool, lock and key or other means of security. Statement 1072

**Warning**

Voice over IP (VoIP) service and the emergency calling service do not function if power fails or is disrupted. After power is restored, you might have to reset or reconfigure equipment to regain access to VoIP and the emergency calling service. In the USA, this emergency number is 911. You need to be aware of the emergency number in your country. Statement 371

**Caution**

Category 5e and Category 6 cables can store high levels of static electricity. Always ground the cables to a suitable and safe earth ground before connecting them to the switch or other devices.

**Caution**

Noncompliant cabling or powered devices can cause a PoE port fault. Use only standard-compliant cabling to connect Cisco prestandard IP Phones and wireless access points, IEEE 802.3af, or 802.3at (PoE+)-compliant devices. You must remove any cable or device that causes a PoE fault.

## Where to Go Next

If the default configuration is satisfactory, the switch does not need further configuration. You can use any of these management options to change the default configuration:

- Start the Network Assistant application, which is described in the getting started guide. Through this GUI, you can configure and monitor a switch cluster or an individual switch.
- Use the CLI to configure the switch as a member of a cluster or as an individual switch from the console.
- Use the Cisco Prime Infrastructure application.
- If you are using Cisco IOS XE Denali 16.1.x and later releases, see the *Configuring the Switch* chapter in this guide for information about setting up the switch.





## CHAPTER 3

# Installing a Network Module

- Network Module Overview, on page 53
- Installing a Network Module in the Switch, on page 58
- Removing a Network Module, on page 64
- Installing SFP and SFP+ Modules, on page 65
- Removing SFP and SFP+ Modules, on page 66
- Finding the Network Module Serial Number, on page 67

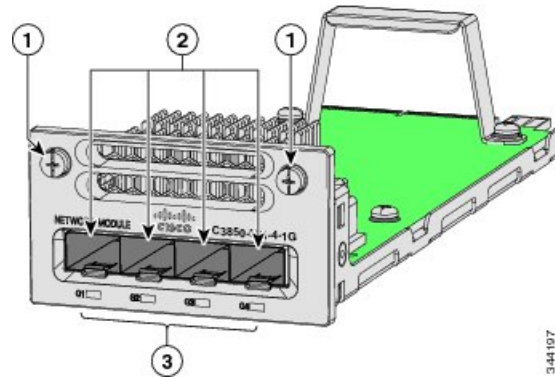
## Network Module Overview

Network Module <sup>13</sup>	Description
C3850-NM-4-1G	<p>This module has four 1 G SFP module slots. Any combination of standard SFP modules are supported. SFP+ modules are not supported.</p> <p>If you insert an SFP+ module in the 1 G network module, the SFP+ module does not operate, and the switch logs an error message.</p> <p><b>Note</b> This is supported on the following switch models:</p> <ul style="list-style-type: none"><li>• WS-C3850-24T/P/U</li><li>• WS-C3850-48T/F/P/U</li><li>• WS-C3850-12X48U</li><li>• WS-C3850-24XU</li><li>• WS-C3850-12S</li><li>• WS-C3850-24S</li></ul>

Network Module <sup>13</sup>	Description
C3850-NM-2-10G	<p>This module has four slots:</p> <p>Two slots (left side) support only 1 G SFP modules and two slots (right side) support either 1 G SFP or 10 G SFP modules.</p> <p><b>Note</b> This is supported on the following switch models:</p> <ul style="list-style-type: none"> <li>• WS-C3850-24T/P/U</li> <li>• WS-C3850-48T/F/P/U</li> <li>• WS-C3850-12X48U</li> <li>• WS-C3850-24XU</li> <li>• WS-C3850-12S</li> <li>• WS-C3850-24S</li> </ul>
C3850-NM-4-10G	<p>This module has four 10 G slots or four 1 G slots.</p> <p><b>Note</b> This is supported on the following switch models:</p> <ul style="list-style-type: none"> <li>• WS-C3850-48T/F/P/U</li> <li>• WS-C3850-12X48U</li> <li>• WS-C3850-24XU</li> <li>• WS-C3850-12XS</li> <li>• WS-C3850-24XS</li> </ul>
C3850-NM-8-10G	<p>This module has eight 10 G slots with an SFP+ port in each slot. Each port supports a 1 G or 10 G connection</p> <p><b>Note</b> This is supported on the following switch models:</p> <ul style="list-style-type: none"> <li>• WS-C3850-12X48U</li> <li>• WS-C3850-24XU</li> <li>• WS-C3850-24XS</li> </ul>
C3850-NM-2-40G	<p>This module has two 40 G slots with a QSFP+ connector in each slot.</p> <p><b>Note</b> This is supported on the following switch models:</p> <ul style="list-style-type: none"> <li>• WS-C3850-12X48U</li> <li>• WS-C3850-24XU</li> <li>• WS-C3850-24XS</li> </ul>
C3850-NM-BLANK	<p>Insert this blank module when the switch has no uplink ports (this is required for sufficient air flow).</p>

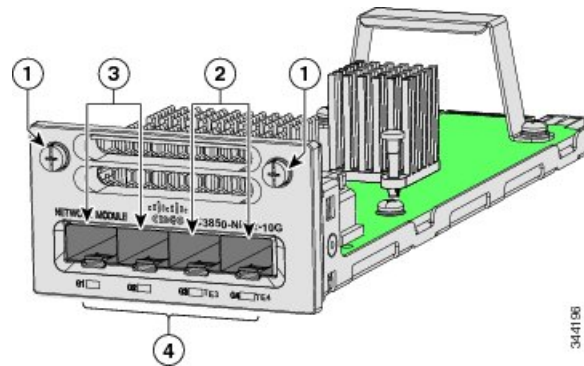
<sup>13</sup> All network modules are hot-swappable.

**Figure 34: C3850-NM-4-1G Network Module**



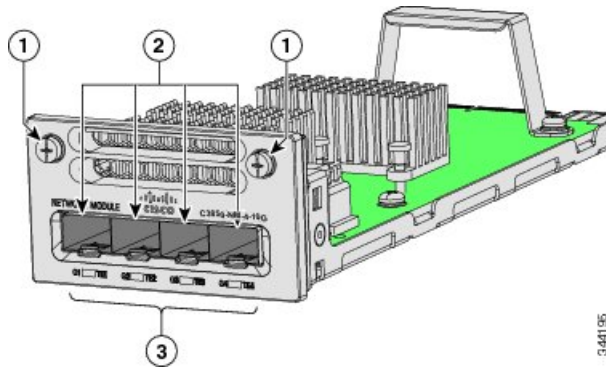
1	Captive screws	3	LEDs
2	1 G Ethernet SFP slots		

**Figure 35: C3850-NM-2-10G Network Module**



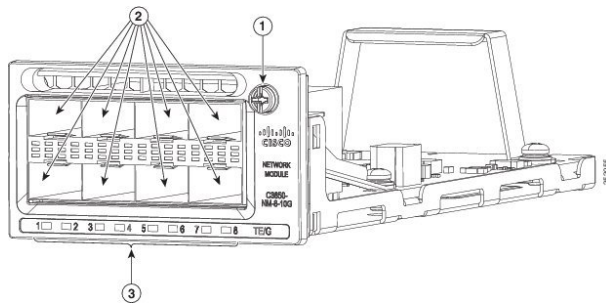
1	Captive screws	3	1 G Ethernet SFP slots
2	1 G or 10 G Ethernet SFP+ slots	4	LEDs

Figure 36: C3850-NM-4-10G Network Module



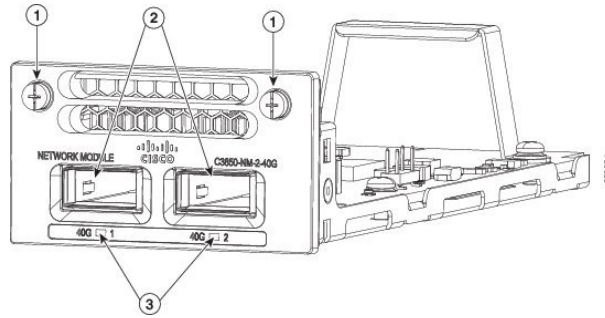
1	Captive screws	3	LEDs
2	10 G slots or 1 G Ethernet SFP slots		

Figure 37: C3850-NM-8-10G Network Module



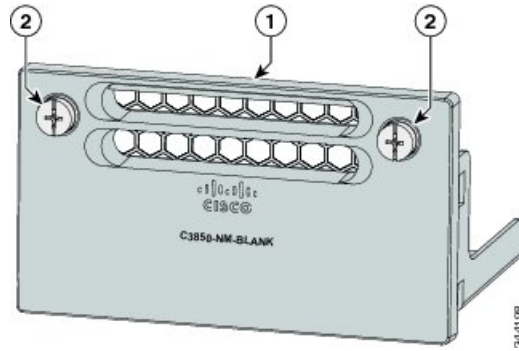
1	Captive screw <b>Note</b> This network module has only one screw. You must fasten the screw completely to secure the module, and loosen the screw first so that the module may be removed.	3	LEDs
2	10 G or 1 G SFP+ slots		

Figure 38: C3850-NM-2-40G Network Module



1	Captive screws	3	LEDs
2	40 G QSFP+ slots		

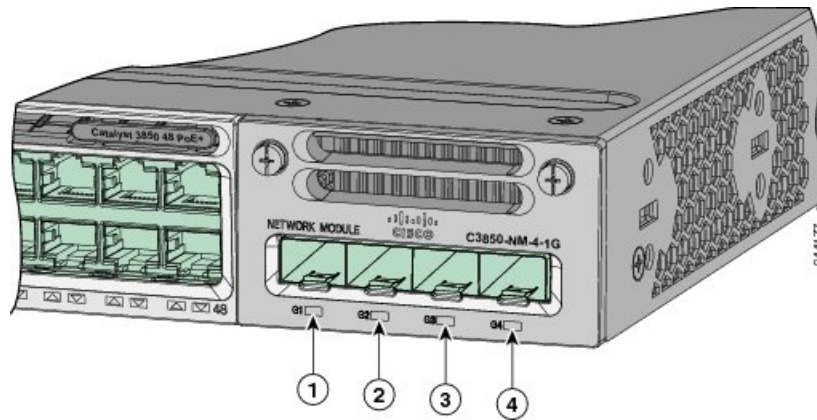
Figure 39: Blank Network Module



1	Blank module	2	Captive screws
---	--------------	---	----------------

## Network Module LEDs

Figure 40: Network Module LEDs



1	G1 LED	3	G3 LED
---	--------	---	--------

2	G2 LED	4	G4 LED
Color	Network Module Link Status		
Off	Link is off.		
Green	Link is on; no activity.		
Blinking green	Activity on a link; no faults. <b>Note</b> The LED will blink green even when there is very little control traffic.		
Blinking amber	Link is off due to a fault or because it has exceeded a limit set in the switch software. <b>Caution</b> Link faults occur when noncompliant cabling is connected to an SFP/SFP+ port. Use only standard-compliant cabling to connect to Cisco SFP/SFP+ ports. You must remove from the network any cable or device that causes a link fault.		
Amber	Link for the SFP/SFP+ has been disabled.		

## Installing a Network Module in the Switch

### Safety Warnings

This section includes the installation cautions and warnings. Translations of the safety warnings appear in the *Regulatory Compliance and Safety Information for the Catalyst 3850 Switches* on Cisco.com: [http://www.cisco.com/go/cat3850\\_hw](http://www.cisco.com/go/cat3850_hw).

Read this section before you install a network module.



#### Caution

Proper ESD protection is required whenever you handle equipment. Installation and maintenance personnel should be properly grounded by grounding straps to eliminate the risk of ESD damage to the equipment. Equipment is subject to ESD damage whenever you remove it.



#### Warning

Only trained and qualified personnel should be allowed to install, replace, or service this equipment. Statement 1030



#### Warning

Do not reach into a vacant slot or chassis while you install or remove a module. Exposed circuitry could constitute an energy hazard. Statement 206

## Equipment That You Need

- Ratcheting torque screwdriver with a number-2 Phillips head that exerts up to 15 pound-force inches (lbf-in.) of pressure.
- Panduit crimping tool with optional controlled-cycle mechanism (model CT-720, CT-920, CT-920CH, CT-930, or CT-940CH).
- Wire-stripping tools.
- 12-gauge copper ground wire (insulated or not) for the single-hole ground connection.
- 8-gauge copper ground wire (insulated or not) for the dual-hole ground connection.
- Dual-hole ground lug and two screws (included in the DC power supply accessory kit) and single-hole ground lug and screw (included in the switch accessory kit). The dual-hole lug is required for the grounding of the switch in a NEBS installation where the DC supply is the only NEBS compliant power supply option.
- Four leads of 14-gauge copper wire.
- Four fork-type terminals from the DC power supply accessory kit. The terminals must be the proper size for M3 screws in a Dinkle DT-35-B25-style terminal block.

## Installing Network Modules



---

**Note** The switch can operate without a network module, but a blank module (with no ports or SFP slots) is available and should be installed when uplink ports are not required.

---



---

**Note** The switch generates logs when you insert or remove a network module with SFP slots.

---

Use only supported network modules and SFP or SFP+ modules. Each module has an internal serial EEPROM that is encoded with security information. For information about supported SFP modules, see [SFP and SFP+ Modules, on page 13](#).

The network module is hot-swappable. If you remove a module, replace it with another network module or a blank module.



---

**Note** The switch complies with EMC, safety, and thermal specifications when a network module is present. If no uplink ports are required, install a blank network module.

---

### Before you begin

When installing network modules, observe these precautions:

- Do not remove the blank module from the slot unless you are installing an SFP or SFP+ module. Either a module or a dust plug must be in the slot at all times.

- Do not remove the dust plugs from the fiber-optic SFP modules or the rubber caps from the fiber-optic cable until you connect the cable. The plugs and caps protect the module ports and cables from contamination and ambient light.
- Removing and installing a network module can shorten its useful life. Do not remove and insert a network module more often than is necessary.
- To prevent ESD damage, follow your normal board and component handling procedures when connecting cables to the switch and other devices.

## Procedure

**Step 1** Attach an ESD-preventive wrist strap to your wrist and to an earth ground surface.

**Step 2** Remove the module from the protective packaging.

**Step 3** Remove the blank module from the switch and save it.

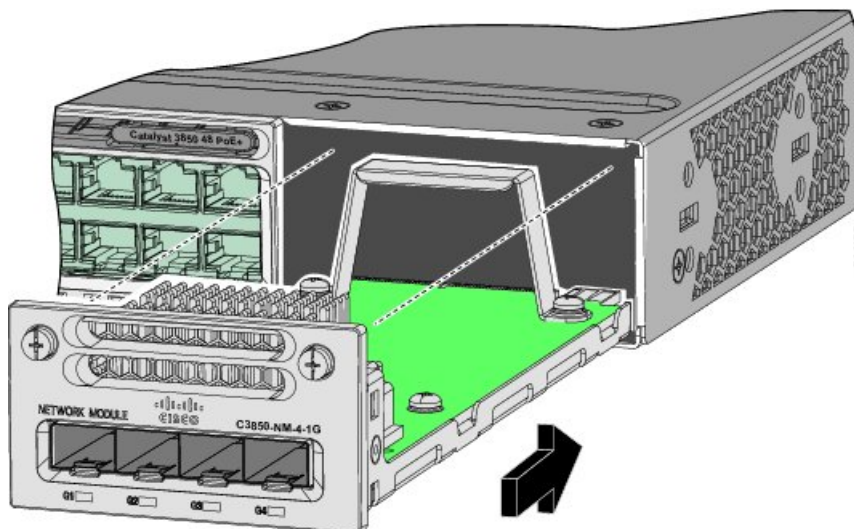
**Caution** Verify the correct orientation of your module before installing it. Incorrect installation can damage the module.

**Caution** Do not install the network module with connected cables or installed SFP modules. Always remove any cables and modules before you install the network module.

**Caution** A module interface might become error-disabled when a network module with connected fiber-optic cables is installed or removed. If an interface is error-disabled, you can reenble the interface by using the **shutdown** and **no shutdown** interface configuration commands.

**Step 4** Position the module face up to install it in the module slot. Slide the module into the slot until the back of the module faceplate is flush with the switch faceplate. Fasten the captive screws to secure the network module in place.

**Figure 41: Installing the Network Module in the Switch**



- Note** Unlike other network modules, the C3850-NM-8-10G cannot be fully inserted and secured until the jackscrew is properly tightened.
1. Push the module into the uplink slot until the jackscrew connects with the rightmost tab.
  2. You will feel some light resistance, because a spring-loaded tab inside the slot will push back against the C3850-NM-8-10G module
  3. Continue to tighten the jackscrew while gently pushing the front panel of the network module into the slot.

## Network Module Port Configurations

### C3850-NM-4-1G Module

All ports in the C3850-NM-4-1G module are natively GigabitEthernet and are configured GigabitEthernet1/1/1 through GigabitEthernet1/1/4. There are only four interfaces that are valid, and the other four should not be used even though they still show up in the CLI.

*Table 20: C3850-NM-4-1G Module*

Interface	Action
GigabitEthernet1/1/1	Configure this interface
GigabitEthernet1/1/2	Configure this interface
GigabitEthernet1/1/3	Configure this interface
GigabitEthernet1/1/4	Configure this interface
TenGigabitEthernet1/1/1	Disregard
TenGigabitEthernet1/1/2	Disregard
TenGigabitEthernet1/1/3	Disregard
TenGigabitEthernet1/1/4	Disregard

### C3850-NM-4-10G Module

All ports in the C3850-NM-4-10G module default to 10 G and should be configured as TenGigabitEthernet1/1/1 through TenGigabitEthernet1/1/4, even when you are operating them as 1 G using SFPs. Only four interfaces are valid; the other four should not be used even though they still show up in the CLI.

*Table 21: C3850-NM-4-10G Module*

Interface	Action
GigabitEthernet1/1/1	Disregard
GigabitEthernet1/1/2	Disregard

Interface	Action
GigabitEthernet1/1/3	Disregard
GigabitEthernet1/1/4	Disregard
TenGigabitEthernet1/1/1	Configure this interface
TenGigabitEthernet1/1/2	Configure this interface
TenGigabitEthernet1/1/3	Configure this interface
TenGigabitEthernet1/1/4	Configure this interface

## C3850-NM-2-10G Module

In the C3850-NM-2-10G module, the first two ports are natively 1-G ports and the last two ports are natively 10-G ports. So, you configure the 1-G ports as GigabitEthernet1/1/1 through GigabitEthernet1/1/2, and configure the last two ports as TenGigabitEthernet1/1/3 through TenGigabitEthernet1/1/4, even when you are operating the last two ports as 1-G. Only four interfaces are valid, and the other four should not be used even though they still show up in the CLI.

*Table 22: C3850-NM-2-10G Module*

Interface	Action
GigabitEthernet1/1/1	Configure this interface
GigabitEthernet1/1/2	Configure this interface
GigabitEthernet1/1/3	Disregard
GigabitEthernet1/1/4	Disregard
TenGigabitEthernet1/1/1	Disregard
TenGigabitEthernet1/1/2	Disregard
TenGigabitEthernet1/1/3	Configure this interface, even when operating as 1-G
TenGigabitEthernet1/1/4	Configure this interface, even when operating as 1-G

## C3850-NM-8-10G Module

All ports in the C3850-NM-8-10G module default to 10 G and should be configured as TenGigabitEthernet1/1/1 through TenGigabitEthernet1/1/8, even when you are operating them as 1 G using SFP.

*Table 23: C3850-NM-8-10G Module*

Interface	Action
TenGigabitEthernet1/1/1	Configure this interface
TenGigabitEthernet1/1/2	Configure this interface

Interface	Action
TenGigabitEthernet1/1/3	Configure this interface
TenGigabitEthernet1/1/4	Configure this interface
TenGigabitEthernet1/1/5	Configure this interface
TenGigabitEthernet1/1/6	Configure this interface
TenGigabitEthernet1/1/7	Configure this interface
TenGigabitEthernet1/1/8	Configure this interface

## C3850-NM-2-40G Module

The default port connections for the C3850-NM-2-40G module depends on whether you use a 40 G QSFP module or a 4x10G breakout cable.

If you use a 40 G QSFP module, the ports default to 40 G interfaces. In this case, the 10 G interfaces are displayed but not used.

**Table 24: C3850-NM-2-40G Module with 40 G QSFP Module**

Interface	Action
FortyGigabitEthernet1/1/1	Configure this interface
FortyGigabitEthernet1/1/2	Configure this interface
TenGigabitEthernet1/1/1	Disregard
TenGigabitEthernet1/1/2	Disregard
TenGigabitEthernet1/1/3	Disregard
TenGigabitEthernet1/1/4	Disregard
TenGigabitEthernet1/1/5	Disregard
TenGigabitEthernet1/1/6	Disregard
TenGigabitEthernet1/1/7	Disregard
TenGigabitEthernet1/1/8	Disregard

If you use a 4x10G breakout cable, the ports default to 10 G interfaces.

**Table 25: C3850-NM-2-40G Module with 4x10G breakout cable**

Interface	Action
FortyGigabitEthernet1/1/1	Disregard
FortyGigabitEthernet1/1/2	Disregard

Interface	Action
TenGigabitEthernet1/1/1	Configure this interface
TenGigabitEthernet1/1/2	Configure this interface
TenGigabitEthernet1/1/3	Configure this interface
TenGigabitEthernet1/1/4	Configure this interface
TenGigabitEthernet1/1/5	Configure this interface
TenGigabitEthernet1/1/6	Configure this interface
TenGigabitEthernet1/1/7	Configure this interface
TenGigabitEthernet1/1/8	Configure this interface

## Removing a Network Module



**Note** The switch complies with EMC, safety, and thermal specifications when a network module is present. If no uplink ports are required, install a blank network module.



**Note** To avoid authentication failure and non-detection of modules, wait for a minimum of five seconds between the online insertion and removal (OIR) of network modules.

### Procedure

**Step 1** Attach an ESD-preventive wrist strap to your wrist and to an earth ground surface

**Caution** Do not remove the network module with connected cables or installed SFP modules. Always remove any cables and modules before you remove the network module.

**Caution** A module interface might become error-disabled when a network module with connected fiber-optic cables is installed or removed. If an interface is error-disabled, you can reenab the interface by using the **shutdown** and **no shutdown** interface configuration commands.

**Step 2** Disconnect the cables from the SFP modules.

**Step 3** Remove the SFP modules from the network module.

**Step 4** Loosen the captive screws that hold the network module in place.

**Note** The C3850-NM-8-10G module is held secure in the switch by only one jackscrew. This screw also helps to eject the module from its connector interface. Before the module can be removed completely, the screw must be unscrewed all the way out. When removing the screw, a spring pushes the module out when the screw is completely disengaged. Ensure that you hold the module securely until it is completely removed.

- Step 5** Grasp the captive screws, and carefully slide it out of the slot.
- Step 6** Install a replacement network module or a blank module in the slot.
- Step 7** Place the module that you removed in an antistatic bag or other protective environment.
- 

## Installing SFP and SFP+ Modules

### Before you begin

You must have an installed network module to use SFP and SFP+ modules (except for the Catalyst WS-C3850-12S and WS-C3850-24S). The downlink ports on the Catalyst WS-C3850-12S and WS-C3850-24S switch models support standard SFP modules, and the downlink ports on the Catalyst WS-C3850-12XS and WS-C3850-24XS switch models support standard SFP+ modules.

See the switch release notes on Cisco.com for the list of supported SFP and SFP+ modules. Use only supported SFP modules on the switch. For the latest information about supported SFP and SFP+ modules, refer to the Cisco Transceiver Modules Compatibility Information at

[http://www.cisco.com/en/US/products/hw/modules/ps5455/products\\_device\\_support\\_tables\\_list.html](http://www.cisco.com/en/US/products/hw/modules/ps5455/products_device_support_tables_list.html)

For information about installing, removing, cabling, and troubleshooting SFP modules, see the module documentation that shipped with your device.

Observe these precautions:



**Warning** Class 1 laser product. Statement 1008

---

- Do not remove the dust plugs from the SFP modules or the rubber caps from the fiber-optic cable until you are ready to connect the cable. The plugs and caps protect the module ports and cables from contamination and ambient light.
- Removing and installing an SFP module can shorten its useful life. Do not remove and insert any SFP module more often than is necessary.
- To prevent ESD damage, follow your normal board and component handling procedures when connecting cables to the switch and other devices.
- When you insert several SFPs in multiple switch ports, wait for 5 seconds between inserting each SFP. This will prevent the ports from going into error disabled mode. Similarly, when you remove an SFP from a port, wait for 5 seconds before reinserting it.

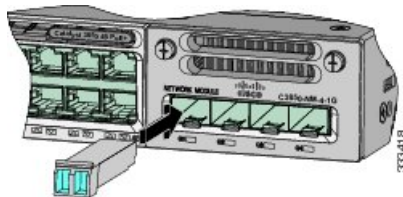
### Procedure

---

- Step 1** Attach an ESD-preventive wrist strap to your wrist and to an earth ground surface.

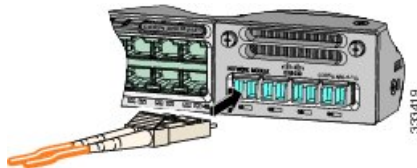
- Step 2** Find the send (TX) and receive (RX) markings that identify the top of the SFP module.  
On some SFP modules, the send and receive (TX and RX) markings might be shown by arrows that show the direction of the connection.
- Step 3** If the SFP module has a bale-clasp latch, move it to the open, unlocked position.
- Step 4** Align the module in front of the slot opening, and push until you feel the connector snap into place.

*Figure 42: Installing an SFP Module in the Network Module*



- Step 5** If the module has a bale-clasp latch, close it to lock the SFP module in place.
- Step 6** Remove the SFP dust plugs and save.
- Step 7** Connect the SFP cables.

*Figure 43: Network Module with SFP Modules Installed*



## Removing SFP and SFP+ Modules

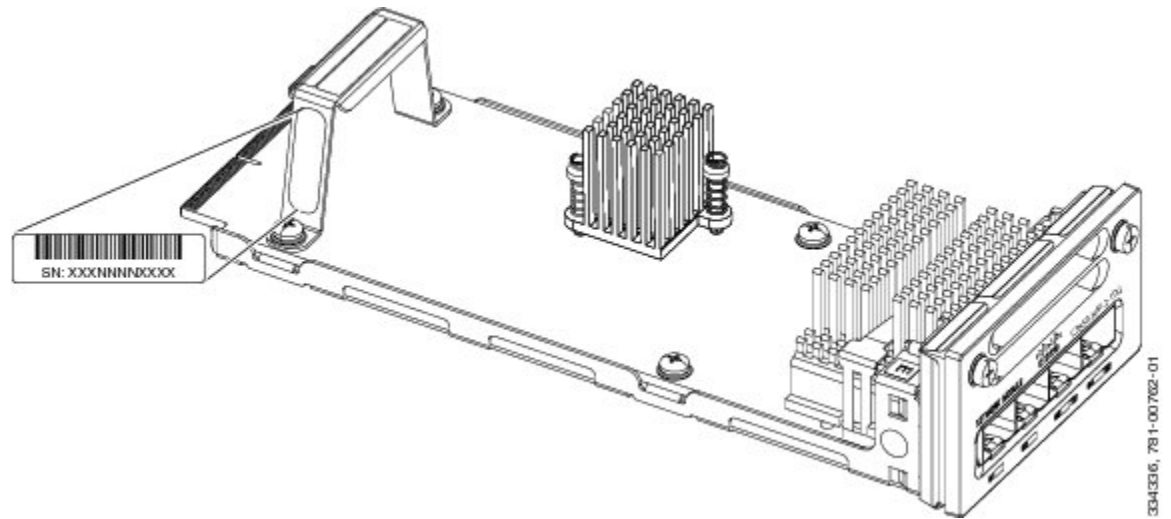
### Procedure

- Step 1** Attach an ESD-preventive wrist strap to your wrist and to an earth ground surface.
- Step 2** Disconnect the cable from the SFP/SFP+ module. For reattachment, note which cable connector plug is send (TX) and which is receive (RX).
- Step 3** Insert a dust plug into the optical ports of the SFP/SFP+ module to keep the optical interfaces clean.
- Step 4** If the module has a bale-clasp latch, pull the bale out and down to eject the module. If you cannot use your finger to open the latch, use a small, flat-blade screwdriver or other long, narrow instrument to open it.
- Step 5** Grasp the SFP/SFP+ module, and carefully remove it from the slot.
- Step 6** Place the SFP/SFP+ module in an antistatic bag or other protective environment.

## Finding the Network Module Serial Number

If you contact Cisco Technical Assistance regarding a network module, you need to know its serial number.

*Figure 44: Network Module Serial Number Location*







## CHAPTER 4

# Power Supply Installation

- [Power Supply Module Overview, on page 69](#)
- [Installation Guidelines, on page 72](#)
- [Installing or Replacing an AC Power Supply, on page 74](#)
- [Installing a DC Power Supply, on page 75](#)
- [Finding the Power Supply Module Serial Number, on page 80](#)

## Power Supply Module Overview

The switch operates with either one or two active power supply modules. A Catalyst 3850 switch that is part of a StackPower stack operates with power supplied by other stack switches.

You can use two AC modules, two DC modules, one AC and one DC module, or one module and a blank cover.



**Note** In a NEBS installation, you can use two DC modules or one DC module and a blank cover.

All power supply modules have internal fans. All switches ship with a blank cover in the second power supply slot.

The following table describes the supported internal power supply modules.

**Table 26: Power Supply Module Part Numbers and Descriptions**

Part Number	Description
PWR-C1-1100WAC=	1100-W AC power supply module
PWR-C1-715WAC=	715-W AC power supply module
PWR-C1-350WAC=	350-W AC power supply module
CPWR-C1-440WDC=	440-W DC power supply module
PWR-C3-750WAC-R	750-W AC power supply module
PWR-C3-750WAC-F	750-W AC power supply module

Part Number	Description
PWR-C3-750WDC-R	750-W DC power supply module
PWR-C3-750WDC-F	750-W DC power supply module
PWR-C1-BLANK	Blank cover

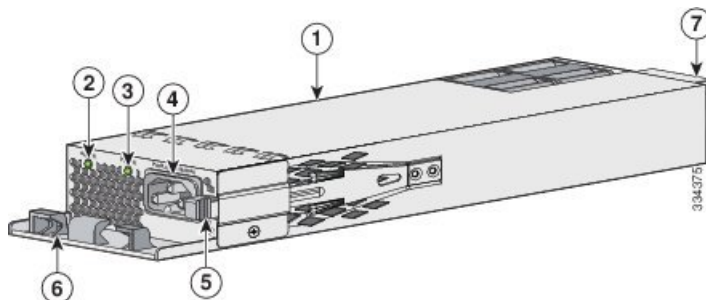
For information on available PoE, PoE+, and UPOE and PoE requirements, see these sections the [Power Supply Modules](#), on page 25.

The 350-W and 715-W AC power supply modules are autoranging units that support input voltages between 100 and 240 VAC. The 1100-W power supply module is an autoranging unit that supports input voltages between 115 and 240 VAC. The 440-W DC power supply module has dual input feeds (A and B) and supports input voltages between 36 and 72 VDC. The output voltage range is 51 to 57 V.

Each AC power supply module has a power cord for connection to an AC power outlet. The 1100-W and 715-W modules use a 16-AWG cord (only North America). All other modules use an 18-AWG cord. The DC power supply module must be wired to a DC power source.

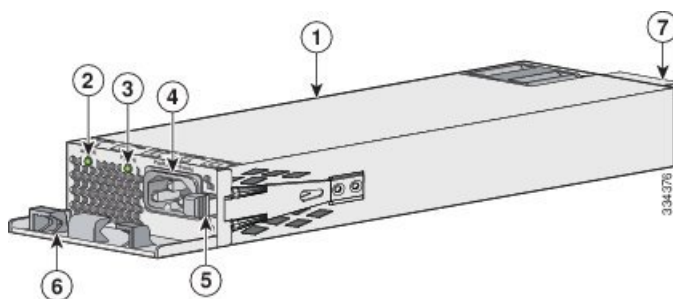
The following illustrations show the power supply modules.

**Figure 45: 1100-W AC Power Supply**



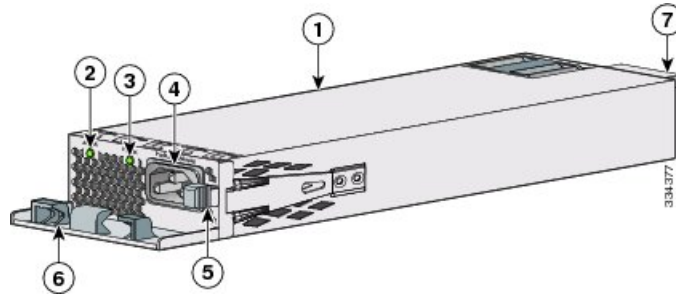
1	1100-W AC power supply module	5	Release latch
2	AC OK LED	6	Power cord retainer
3	PS OK LED	7	Keying feature
4	AC power cord connector		

**Figure 46: 715-W AC Power Supply**



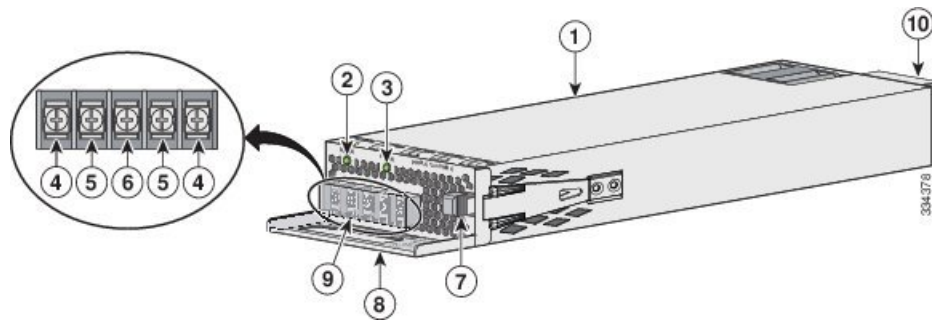
1	715-W AC power supply module	5	Release latch
2	AC OK LED	6	Power cord retainer
3	PS OK LED	7	Keying feature
4	AC power cord connector		

Figure 47: 350-W AC Power Supply



1	350-W AC power supply module	5	Release latch
2	AC OK LED	6	Power cord retainer
3	PS OK LED	7	Keying feature
4	AC power cord connector		

Figure 48: 440-W DC Power Supply



1	440-W DC power supply module	6	Grounding terminal
2	AC OK LED	7	Release latch
3	PS OK LED	8	Extraction handle
4	Input power terminals (positive polarity)	9	Terminal block safety cover

5	Input power terminals (negative polarity)	10	Keying feature
---	---	----	----------------

If no power supply is installed in a power supply slot, install a power supply slot cover.

Figure 49: Power Supply Slot Cover



1	Release handles	2	Retainer clips
---	-----------------	---	----------------

Table 27: Switch Power Supply Module LEDs

AC OK DC OK	Description	PS OK	Description
Off	No AC input power. No DC input power.	Off	Output is disabled, or input is outside operating range (AC LED is off). Output is disabled, or input is outside operating range (DC LED is off).
Green	AC input power present. DC input power present.	Green	Power output to switch active.
		Red	Output has failed.

## Installation Guidelines

Observe these guidelines when removing or installing a power supply or fan module:

- Do not force the power supply or fan module into the slot. This can damage the pins on the switch if they are not aligned with the module.
- A power supply that is only partially connected to the switch can disrupt the system operation.
- Remove power from the power-supply module before removing or installing the module.
- The power supply is hot-swappable. In some configurations, such as full PoE+ or power sharing mode, removing a power supply causes powered devices to shut down until the power budget matches the input power of a single power supply. To minimize network interruption, hot swap the power supply under these circumstances:
  - The switch is in StackPower mode and sufficient power is available.
  - The switch is powered by other switches in a power stack, and no active backup is in progress.

For the switch commands that display available power budget, see the software configuration guide.

- The airflow for C3850-48XS switches will depend on the power supply and fans installed. Ensure that the power supplies are inserted correctly to match the corresponding fans. Power supplies with blue handles correspond to fans with blue handles, and power supplies with red handles correspond to fans with red handles.
  - For power supplies and fans with red handles, airflow is from the front panel to the rear panel (warm air is ‘pulled out of’ the switch.)
  - For power supplies and fans with blue handles, airflow is from the rear panel to the front panel (cool air is ‘pushed into’ the switch.)




---

**Caution** Do not operate the switch with one power-supply module slot empty. For proper chassis cooling, both module slots must be populated, with either a power supply or a blank module.

---




---

**Warning** This equipment must be grounded. Never defeat the ground conductor or operate the equipment in the absence of a suitably installed ground conductor. Contact the appropriate electrical inspection authority or an electrician if you are uncertain that suitable grounding is available.

Statement 1024

---




---

**Warning** Blank faceplates and cover panels serve three important functions: they prevent exposure to hazardous voltages and currents inside the chassis; they contain electromagnetic interference (EMI) that might disrupt other equipment; and they direct the flow of cooling air through the chassis. Do not operate the system unless all cards, faceplates, front covers, and rear covers are in place.

Statement 1029

---




---

**Warning** Do not reach into a vacant slot or chassis while you install or remove a module. Exposed circuitry could constitute an energy hazard.

Statement 206

---




---

**Warning** Only trained and qualified personnel should be allowed to install, replace, or service this equipment.

Statement 1030

---




---

**Warning** If a Cisco external power system is not connected to the switch, install the provided connector cover on the back of the switch.

Statement 386

---

# Installing or Replacing an AC Power Supply

## Procedure

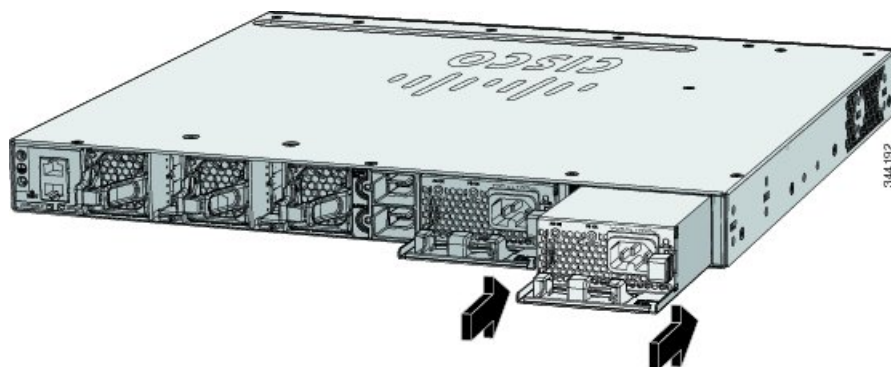
- Step 1** Turn off the power at its source.
- Step 2** Remove the power cord from the power cord retainer.
- Step 3** Remove the power cord from the power connector.
- Step 4** Press the release latch at the right side of the power supply module inward and slide the power supply out.

**Caution** Do not leave the power-supply slot open for more than 90 seconds while the switch is operating.

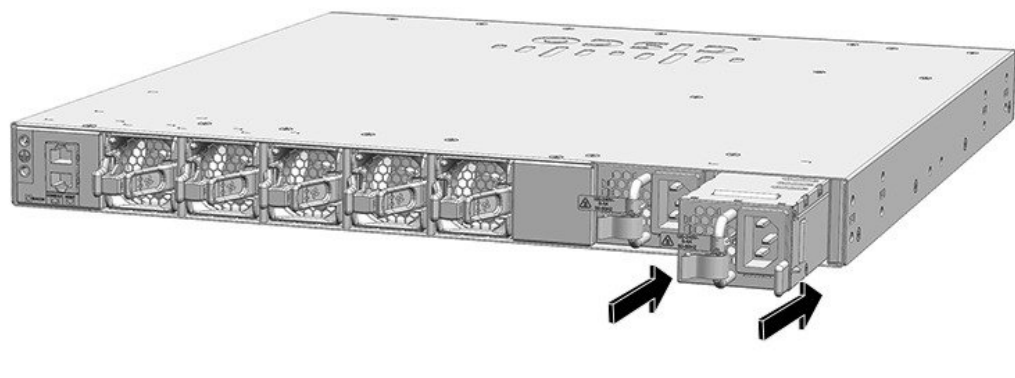
**Warning** This unit might have more than one power supply connection. All connections must be removed to de-energize the unit. Statement 1028

- Step 5** Insert the new power supply into the power-supply slot, and gently push it into the slot. When correctly inserted, the 350-W and 715-W power supplies (excluding the power cord retainer) are flush with the switch rear panel. The 1100-W power-supply module extends 1.5 inches from the switch rear panel.

*Figure 50: Inserting the AC-Power Supply in the Catalyst WS-C3850 Switch*



*Figure 51: Inserting the AC-Power Supply in the Catalyst WS-C3850-48XS Switch*



- Step 6** (Optional) Make a loop in the power cord and thread it through the power cord retainer.

Figure 52: AC-Power Supply with Power Cord Retainer

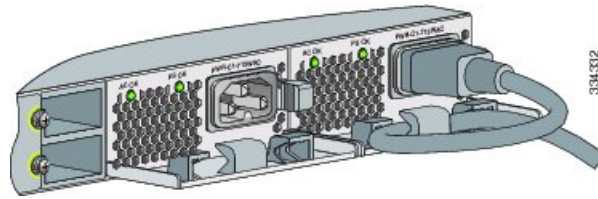
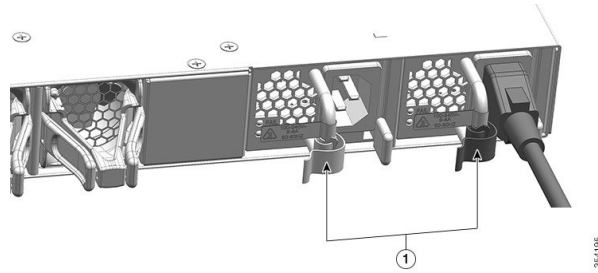



Figure 53: AC-Power Supply with Velcro Strap





1	Velcro strap
---	--------------


- Step 7** Connect the power cord to the power supply and to an AC power outlet. Turn on the power at the power source.
- Step 8** Confirm that the power supply AC OK and PS OK LEDs are green.

## Installing a DC Power Supply

- 

**Warning** An exposed wire lead from a DC-input power source can conduct harmful levels of electricity. Be sure that no exposed portion of the DC-input power source wire extends from the terminal block plug. Statement 122
- 

**Warning** Before performing any of the following procedures, ensure that power is removed from the DC circuit. Statement 1003
- 

**Warning** This product relies on the building's installation for short-circuit (overcurrent) protection. Ensure that the protective device is rated not greater than: 20 A. Statement 1005
- 

**Warning** A readily accessible two-poled disconnect device must be incorporated in the fixed wiring. Statement 1022

**Warning**

Hazardous voltage or energy may be present on power terminals. Always replace cover when terminals are not in service. Be sure uninsulated conductors are not accessible when cover is in place. Statement 1086

**Note**

The grounding architecture of this product is DC-isolated (DC-I).

## Equipment That You Need

- Ratcheting torque screwdriver with a number-2 Phillips head that exerts up to 15 pound-force inches (lbf-in.) of pressure.
- Panduit crimping tool with optional controlled-cycle mechanism (model CT-720, CT-920, CT-920CH, CT-930, or CT-940CH).
- Wire-stripping tools.
- 12-gauge copper ground wire (insulated or not) for the single-hole ground connection.
- 8-gauge copper ground wire (insulated or not) for the dual-hole ground connection.
- Dual-hole ground lug and two screws (included in the DC power supply accessory kit) and single-hole ground lug and screw (included in the switch accessory kit). The dual-hole lug is required for the grounding of the switch in a NEBS installation where the DC supply is the only NEBS compliant power supply option.
- Four leads of 14-gauge copper wire.
- Four fork-type terminals from the DC power supply accessory kit. The terminals must be the proper size for M3 screws in a Dinkle DT-35-B25-style terminal block.

## Grounding the Switch

Follow these steps to install either a single-hole ground lug or a dual-hole ground lug on the switch. Make sure to follow any grounding requirements at your site.

### Before you begin

Follow the grounding procedures at your site and observe these warnings:

**Warning**

This equipment must be grounded. Never defeat the ground conductor or operate the equipment in the absence of a suitably installed ground conductor. Contact the appropriate electrical inspection authority or an electrician if you are uncertain that suitable grounding is available. Statement 1024

**Warning**

When installing or replacing the unit, the ground connection must always be made first and disconnected last. Statement 1046



**Caution** Follow the grounding procedure instructions, and use a UL-listed lug (included in the accessory kit).



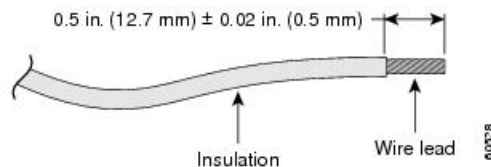
**Caution** To comply with the Telcordia GR-1089 NEBS standard for electromagnetic compatibility and safety, connect the (Management Ethernet) ports only to intra-building or unexposed wiring or cable. The intrabuilding cable must be shielded and the shield must be grounded at both ends. The intra-building port(s) of the equipment or subassembly must not be metallically connected to interfaces that connect to the OSP or its wiring. These interfaces are designed for use as intra-building interfaces only (Type 2 or Type 4 ports as described in GR-1089-CORE) and require isolation from the exposed OSP cabling. The addition of Primary Protectors is not sufficient protection in order to connect these interfaces metallically to OSP wiring.

### Procedure

**Step 1** Use the ground lug screw and the lug ring for a single-ground connection. Use the dual-hole lug for a ground connection in a NEBS installation.

**Step 2** Strip the 12-gauge or 8-gauge ground wire to 0.5 inch (12.7 mm)  $\pm$  0.02 inch (0.5 mm). Stripping more than the recommended amount of wire can leave exposed wire from the connector. Use 12-gauge copper ground wire for the single-ground connection. Use 8-gauge copper ground wire for the dual-ground connection.

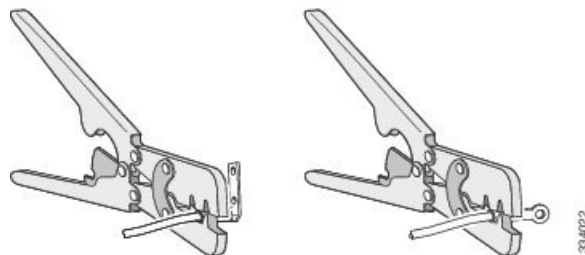
**Figure 54: Stripping the Ground Wire**



**Step 3** Slide the open end of the ground lug over the exposed area of the wire.

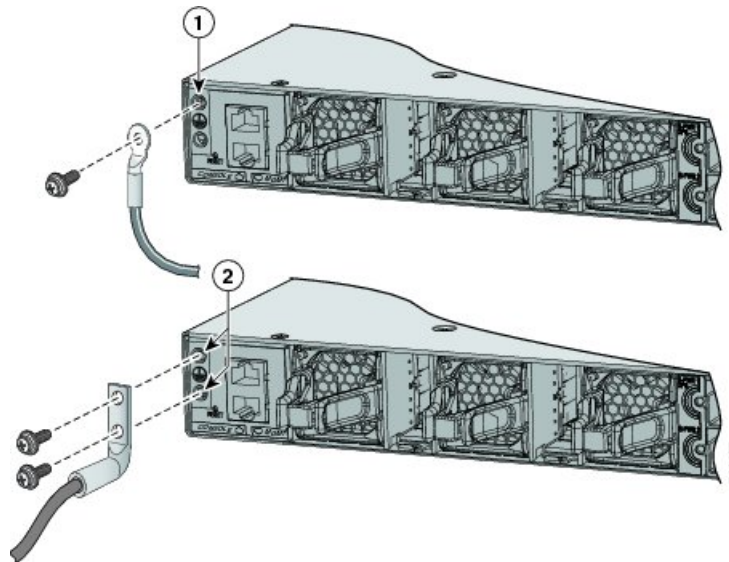
**Step 4** Using a Panduit crimping tool, crimp the ground lug to the wire.

**Figure 55: Crimping the Ground Lug**



**Step 5** Use the ground screw to attach the single-ground lug to the switch rear panel. Use two ground screws to attach the dual-hole lug to the switch rear panel.

Figure 56: Attaching the Ground Lug and Wire Assembly



1	Single-hole ground screw and lug ring	2	Dual-hole ground adapter and dual-hole lug
---	---------------------------------------	---	--

**Step 6** Using a ratcheting torque screwdriver, torque the ground-lug screws to 60 lbf-in. (960 ozf-in.).

**Step 7** Connect the other end of the grounding wire to an appropriate grounding point at your site or to the rack.

## Installing the DC Power Supply in the Switch

### Before you begin

Before installing the power supply, see the [Installation Guidelines](#), on page 72.

### Procedure

**Step 1** Turn off DC power. To ensure that power is off, change the circuit breakers to the OFF position, and tape the circuit-breaker switches in the OFF position.

**Step 2** Remove the plastic safety cover from the power supply terminal blocks.

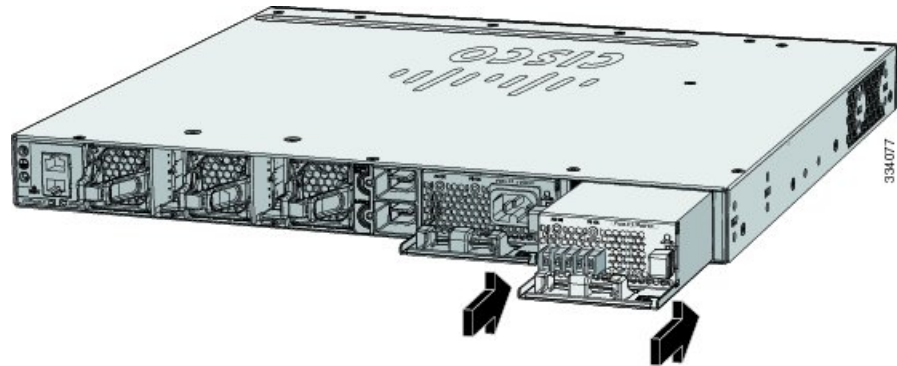
**Note** If you are not replacing a DC power supply, go to Step 5.

**Step 3** Use a number-2 Phillips screwdriver to remove the DC-input power wires from the power terminals.

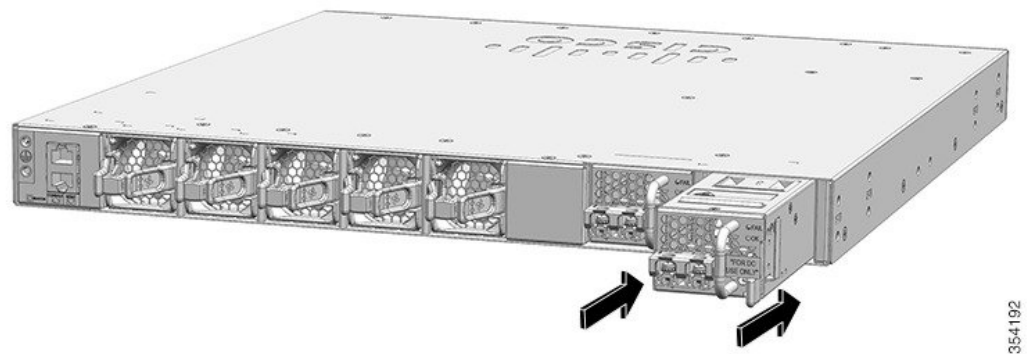
**Step 4** Press the release latch at the right side of the power supply module inward, and pull the power supply out.

**Step 5** Insert the power supply in the power-supply slot, and gently push it into the slot. When correctly installed, the DC power supply (excluding the extraction handle) is flush with the switch rear panel.

*Figure 57: Inserting the DC-Power Supply in the Catalyst WS-C3850 Switch*



*Figure 58: Inserting the DC-Power Supply in the Catalyst WS-C3850-48XS Switch*

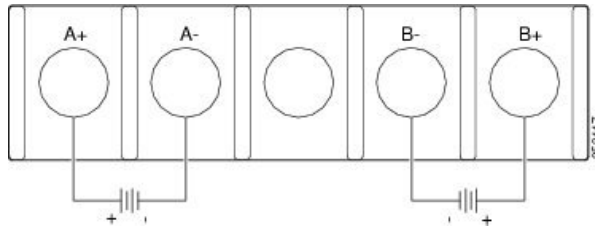
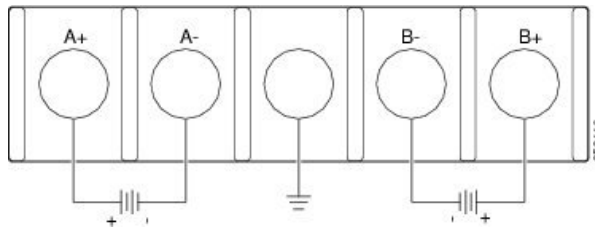


- Step 6** Connect the input power as described in [Wiring the DC Input Power Source](#), on page 79.

## Wiring the DC Input Power Source

### Procedure

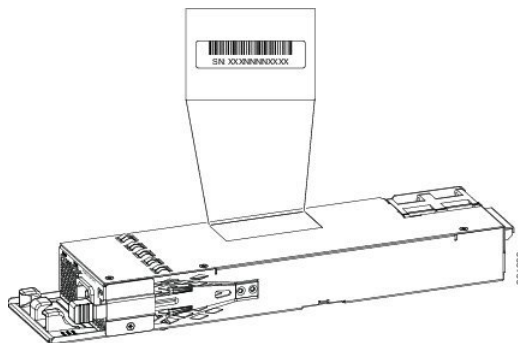
- Step 1** Using a wire-stripping tool, strip each of the four wires from the DC-input power source to the appropriate length for the terminals.
- Warning** Use copper conductors only. Statement 1025
- Step 2** Using a Panduit crimping tool, crimp the fork-type terminals to the copper conductor, 90C, 12-AWG DC power input wires.
- Step 3** Connect the DC-input power terminals to the terminal blocks. Make sure to match the polarity (negative to negative, positive to positive) when connecting the wires to the terminal blocks. Connect the ground wire to a grounded metal rack or to earth ground if the switch is not in a grounded rack.

**Figure 59: DC Source A Isolated From Source B with No Common Ground****Figure 60: DC Source A and Source B Connections with Common Ground**

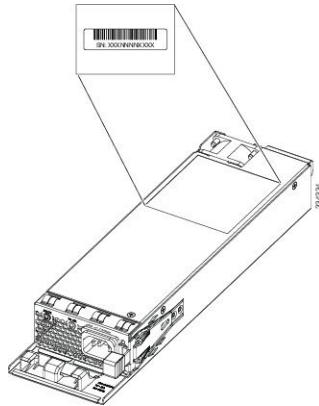
- Step 4** Torque all terminal block screws to 11 lbf-in.
- Step 5** Replace the terminal block safety cover.
- Step 6** Move the DC power source circuit-breakers to the ON position.
- Step 7** Confirm that the power supply DC OK and PS OK LEDs are green.

## Finding the Power Supply Module Serial Number

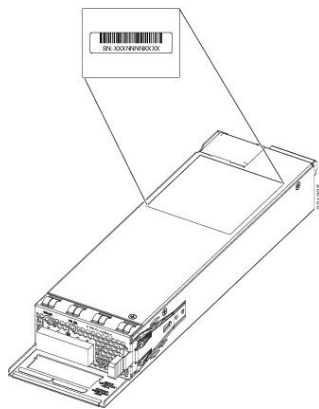
If you contact Cisco Technical Assistance regarding a power supply module, you need to know the serial number. See the following illustrations to find the serial number. You can also use the CLI to find out the serial number.

**Figure 61: 1100-W AC Power Supply Serial Number**

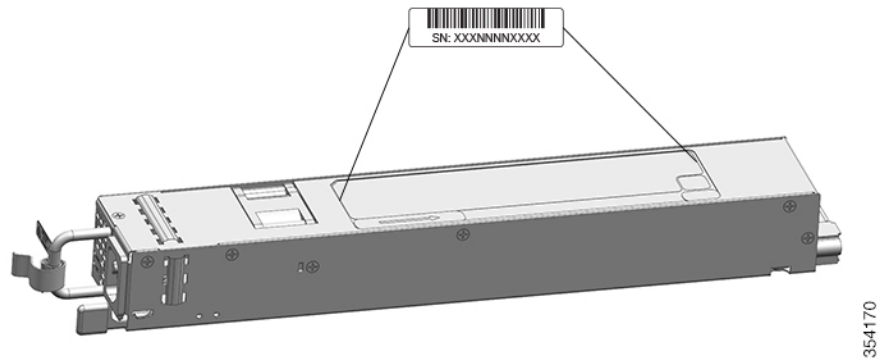
**Figure 62: 715-W and 350-W AC Power Supply Serial Number**



**Figure 63: 440-W DC Power Supply Serial Number**

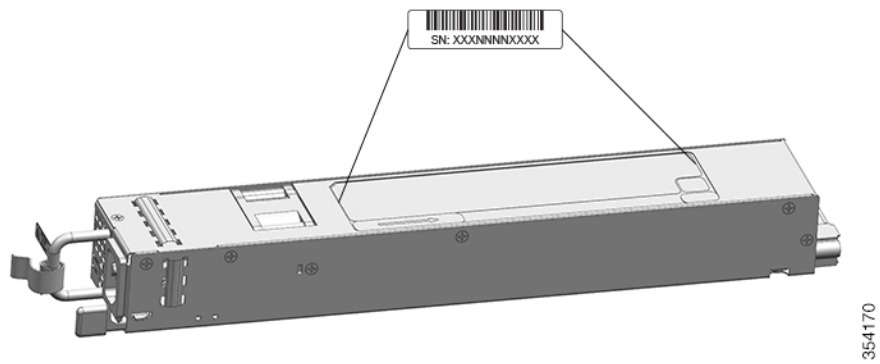


**Figure 64: 750-W AC Power Supply Serial Number**

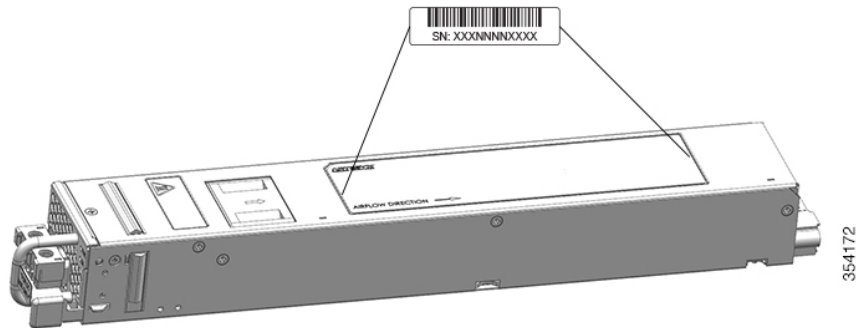


354170

**Figure 65: 750-W AC Power Supply Serial Number**



**Figure 66: 750-W DC Power Supply Serial Number**





# CHAPTER 5

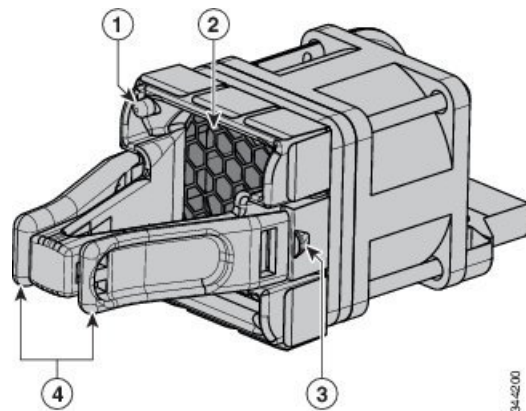
## Installing the Fan

- [Fan Module Overview](#) , on page 83
- [Installation Guidelines](#), on page 84
- [Installing a Fan Module](#), on page 85
- [Finding the Fan Module Serial Number](#), on page 86

### Fan Module Overview

Depending on the switch model, three or five internal hot-swappable are available. A powered switch should always have more than one operational fan. The switch can operate with two operational fans and one nonfunctional fan, but the failed fan should be replaced as soon as possible to avoid a service interruption due to a second fan fault.

**Figure 67: Fan Module for WS-C3850 Switches**

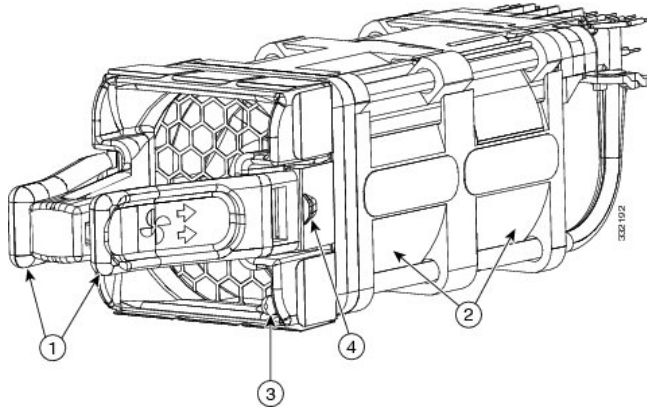


1	Fan LED	3	Retainer clip
2	Exhaust vent	4	Extraction handles



**Note** The WS-C3850 switches require three fans for proper cooling.

Figure 68: Fan Module for Catalyst WS-C3850-48XS Switch Models



1	Fan assembly levers	3	Fan status LED (red/green)
2	Fans	4	Fan assembly retention latch



**Note** Ensure that the power supplies are inserted correctly to match the corresponding fans. Power supplies with blue handles correspond to fans with blue handles, and power supplies with red handles correspond to fans with red handles.



**Note** The WS-C3850-48XS switches require five fans for proper cooling.

## Installation Guidelines

Observe these guidelines when removing or installing a fan module:

- Do not force the fan module into the slot. This can damage the pins on the switch if they are not aligned with the module.
- A fan module that is only partially connected to the switch can disrupt the system operation.
- The switch supports hot swapping of the fan module. You can remove and replace the module without interrupting normal switch operation.



**Warning** Only trained and qualified personnel should be allowed to install, replace, or service this equipment. Statement 1030

# Installing a Fan Module

## Procedure

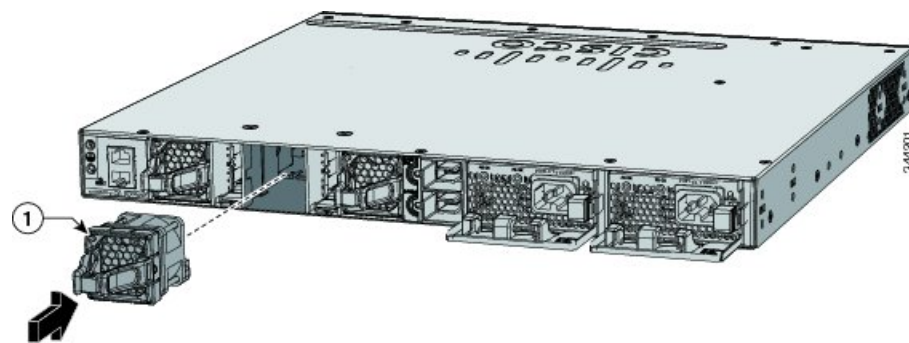
**Step 1** Pinch the fan module release handle, and slide the module out.

**Caution** You should replace the fan module within 5 minutes to avoid overheating the switch.

**Step 2** Install the fan module in the fan slot, and firmly push it into the slot, applying pressure to the end of the module, not the extraction handles. When correctly inserted, the fan module is flush with the switch rear panel. When the fan is operating, a green LED is on in the top left corner of the fan.

**Warning** Do not reach into a vacant slot when installing or removing a module. Exposed circuitry is an energy hazard. Statement 206

*Figure 69: Installing the Fan Module*



1	Fan LED
---	---------

**Note** The airflow for C3850-48XS switches will depend on the power supply and fans installed. Ensure that the power supplies are inserted correctly to match the corresponding fans. Power supplies with blue handles correspond to fans with blue handles, and power supplies with red handles correspond to fans with red handles.

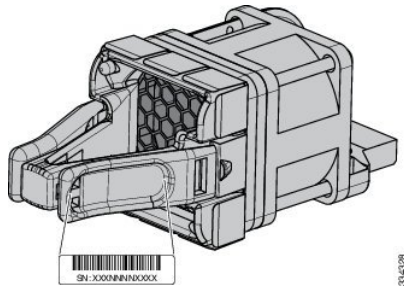
- For power supplies and fans with red handles, airflow is from the front panel to the rear panel (warm air is ‘pulled out of’ the switch.)
- For power supplies and fans with blue handles, airflow is from the rear panel to the front panel (cool air is ‘pushed into’ the switch.)

**Note** Ensure that the fans are inserted correctly to match the corresponding power supplies. Fans with blue handles correspond to power supplies with blue handles, and fans with red handles correspond to power supplies with red handles.

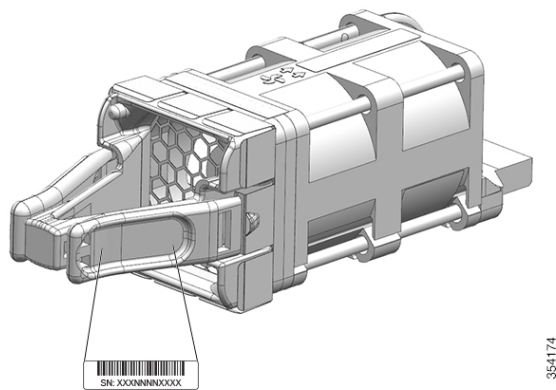
## Finding the Fan Module Serial Number

If you contact Cisco Technical Assistance regarding a fan module, you need to know the fan module serial number. See the following illustration to find the serial number.

**Figure 70: Fan (Single) Module Serial Number**



**Figure 71: Fan (Double) Module Serial Number**





## CHAPTER 6

# Configuring the Switch

---

- [Configuring the Switch Using the Web User Interface, on page 87](#)
- [Configuring the Switch Using the CLI, on page 107](#)

## Configuring the Switch Using the Web User Interface

### Setting up the Switch

After you complete the hardware installation, you need to setup the switch with configuration required to enable traffic to pass through the network. On your first day with your new device, you can perform a number of tasks to ensure that your device is online, reachable and easily configured.

The Web User Interface (Web UI) is an embedded GUI-based device-management tool that provides the ability to provision the device, to simplify device deployment and manageability, and to enhance the user experience. It comes with the default image, so there is no need to enable anything or install any license on the device. You can use WebUI to build configurations, and to monitor and troubleshoot the device without having CLI expertise.

### Connecting to the Switch

#### Before you begin

The bootup script runs the configuration wizard, which prompts you for basic configuration input: (**Would you like to enter the initial configuration dialog? [yes/no]:** ). To configure Day0 settings using the Web UI, do not enter a response. Perform the following tasks instead:

#### Procedure

---

- Step 1** Make sure that no devices are connected to the switch
- Step 2** Connect one end of an ethernet cable to one of the uplink (non-management) ports on the active supervisor and the other end of the ethernet cable to the host (PC).
- Step 3** Set up your PC as a DHCP client, to obtain the IP address of the switch automatically.

It may take up to three mins. You must complete the Day0 setup through the WebUI before using the device terminal.

- Step 4** Launch a Web browser on the PC and enter the device IP address (<https://192.168.1.1>) in the address bar.
- 

#### What to do next

Create a user account.

## Creating User Accounts

Setting a username and password is the first task you will perform on your device. Typically, as a network administrator, you will want to control access to your device and prevent unauthorized users from seeing your network configuration or manipulating your settings.

#### Procedure

---

- Step 1** Log on using the default username and password provided with the device.  
The default username is **cisco**; the default password is the serial number of the switch chassis.
- Step 2** Set a password of up to 25 alphanumeric characters. The username password combination you set gives you privilege 15 access. The string cannot start with a number, is case sensitive, and allows spaces but ignores leading spaces.

Figure 72: Create Account

The screenshot shows the Cisco Configuration Setup Wizard interface. At the top left is the Cisco logo. The title 'Configuration Setup Wizard' is centered at the top. Below the title is a progress bar with two steps: 'CREATE ACCOUNT' (indicated by a blue circle) and 'BASIC SETTINGS' (indicated by a grey circle). The 'CREATE ACCOUNT' step is active, and the text 'Create New Account' is displayed below it. There are three input fields: 'Login Name', 'Password', and 'Confirm password'. The 'Login Name' field is the first, 'Password' is the second, and 'Confirm password' is the third. The interface is clean and professional, with a light green and white color scheme.

**Configuration Setup Wizard**

**CREATE ACCOUNT**      **BASIC SETTINGS**

**Create New Account**

Login Name

Password

Confirm password

## Choosing Setup Options

Select **Wired Network** to configure your device based on a site profile, and continue to configure switch wide settings. Otherwise, continue to the next step and configure only basic settings for your device.

## Configuring Basic Device Settings

On the **Basic Device Settings** page configure the following information:

### Procedure

---

- Step 1** In the **Device ID and Location Settings** section, type a unique name to identify your device in the network.
- Step 2** Choose the date and time settings for your device. To synchronize your device with a valid outside timing mechanism, such as an NTP clock source, choose Automatic, or choose Manual to set it yourself.

Figure 73: Basic Settings - Device ID and Location Settings

The screenshot shows the Cisco Configuration Setup Wizard interface. At the top, the Cisco logo and the title 'Configuration Setup Wizard' are visible. Below the title, a progress bar indicates two steps: 'CREATE ACCOUNT' (completed, marked with a checkmark) and 'BASIC SETTINGS' (current step, marked with a gear icon). The 'Device ID and Location Settings' section includes a text input for 'Device Name', a dropdown menu for 'Date & Time Mode' set to 'Automatic', and a timestamp 'Mon Aug 13 2018 14:18:06'. The 'Device Management Settings' section includes a dropdown for 'Management Interface' set to 'gigabitethernet0/0', and text inputs for 'Management IP', 'Subnet Mask', and 'Default Gateway (optional)', all with placeholder 'x.x.x.x' values. A blue button labeled '< Setup Options' is located at the bottom left of the form.

- Step 3** In the **Device Management Settings** section, assign an **IP address** to the management interface. Ensure that the IP address you assign is part of the subnet mask you enter.
- Step 4** Optionally, enter an **IP address** to specify the default gateway.
- Step 5** To enable access to the device using telnet, check the **Telnet** check box.
- Step 6** To enable secure remote access to the device using Secure Shell (SSH), check the **SSH** check box.
- Step 7** Check the **VTP transparent mode** check box to disable the device from participating in VTP.

If you did not select **Wired Network**, in the earlier step, continue to the next screen to verify your configuration on the **Day 0 Config Summary** screen, and click **Finish**. To automatically configure your device based on a site profile, click **Setup Options**, and select **Wired Network**.

Figure 74: Basic Settings - Device Management Settings

The screenshot shows the Cisco Configuration Setup Wizard interface. At the top, the Cisco logo and the title 'Configuration Setup Wizard' are visible. A progress bar indicates the current step is 'BASIC SETTINGS', which is highlighted with a gear icon and a blue circle. The previous step, 'CREATE ACCOUNT', is marked with a checkmark and a person icon. The date and time 'Mon Aug 13 2018 14:18:37' are displayed. The main section is titled 'Device Management Settings' and contains the following configuration options:

Management Interface	<input type="text" value="gigabitethernet0/0"/>
Management IP	<input type="text" value="x.x.x.x"/>
Subnet Mask	<input type="text" value="x.x.x.x"/>
Default Gateway (optional)	<input type="text" value="x.x.x.x (optional)"/>
Telnet	<input type="checkbox"/>
SSH	<input type="checkbox"/>
VTP transparent mode	<input type="checkbox"/>

At the bottom left, there is a blue button labeled '< Setup Options'.

## Configuring Your Device Based on a Site Profile

To ease your configuration tasks and save time, choose a site profile based on where your device may be installed and managed in your network. Based on the site profile you choose, your device is automatically

configured according to Cisco best practices. You can easily modify this default configuration, from the corresponding detailed configuration screens.

Choosing a site profile as part of Quick Setup allows you to configure your device based on the business needs of your enterprise. For example, you could use your device as an access switch, to connect client nodes and endpoints on your network, or as a distribution switch, to route packets between subnets and VLANs.

**Table 28: Default Configuration Loaded with Each Site Profile (Access Switches)**

Setting	Single Access Switch (Single Uplink)	Single Access Switch (Single Port Channel Uplink)	Single Access Switch (Redundant Port Channel Uplink)
Hostname	The hostname or device name you provided as part of Quick Setup	The hostname or device name you provided as part of Quick Setup	The hostname or device name you provided as part of Quick Setup
Spanning Tree Mode	RPVST+	RPVST+	RPVST+
VTP	Mode Transparent	Mode Transparent	Mode Transparent
UDLD	Enabled	Enabled	Enabled
Error Disable Recovery	Recovery mode set to Auto	Recovery mode set to Auto	Recovery mode set to Auto
Port Channel Load Balance	Source Destination IP	Source Destination IP	Source Destination IP
SSH	Version 2	Version 2	Version 2
SCP	Enabled	Enabled	Enabled
VTY Access to Switch	Enabled	Enabled	Enabled
Service Timestamp	Enabled	Enabled	Enabled
VLAN	The following VLANs are created: <ul style="list-style-type: none"> <li>• Default VLAN</li> <li>• Data VLAN</li> <li>• Voice VLAN</li> <li>• Management VLAN</li> </ul>	The following VLANs are created: <ul style="list-style-type: none"> <li>• Default VLAN</li> <li>• Data VLAN</li> <li>• Voice VLAN</li> <li>• Management VLAN</li> </ul>	The following VLANs are created: <ul style="list-style-type: none"> <li>• Default VLAN</li> <li>• Data VLAN</li> <li>• Voice VLAN</li> <li>• Management VLAN</li> </ul>
Management Interface	Layer 3 settings configured on the management port, based on Quick Setup	Layer 3 settings configured on the management port, based on Quick Setup	Layer 3 settings configured on the management port, based on Quick Setup
IPv6 Host Policy	IPv6 host policy created	IPv6 host policy created	IPv6 host policy created

<b>Setting</b>	<b>Single Access Switch (Single Uplink)</b>	<b>Single Access Switch (Single Port Channel Uplink)</b>	<b>Single Access Switch (Redundant Port Channel Uplink)</b>
QoS Policy for Downlink Ports	Auto QoS Policy for Access defined	Auto QoS Policy for Access defined	Auto QoS Policy for Access defined
QoS Policy for Uplink Ports	QoS Policy for Distribution created	QoS Policy for Distribution created	QoS Policy for Distribution created
Uplink Interfaces	Selected uplink interfaces configured as trunk ports, set to allow all VLANs	Selected ports configured as Port-channel in trunk mode, set to allow all VLANs.	Selected ports configured as Port-channel in trunk mode, set to allow all VLANs.
Downlink Interfaces	Downlink ports configured in Access mode	Downlink ports configured in Access mode	Downlink ports configured in Access mode
Port-channel	Not configured	Port-channel to distribution created	Port-channel to distribution created

Figure 75: Site Profile - Access Switches

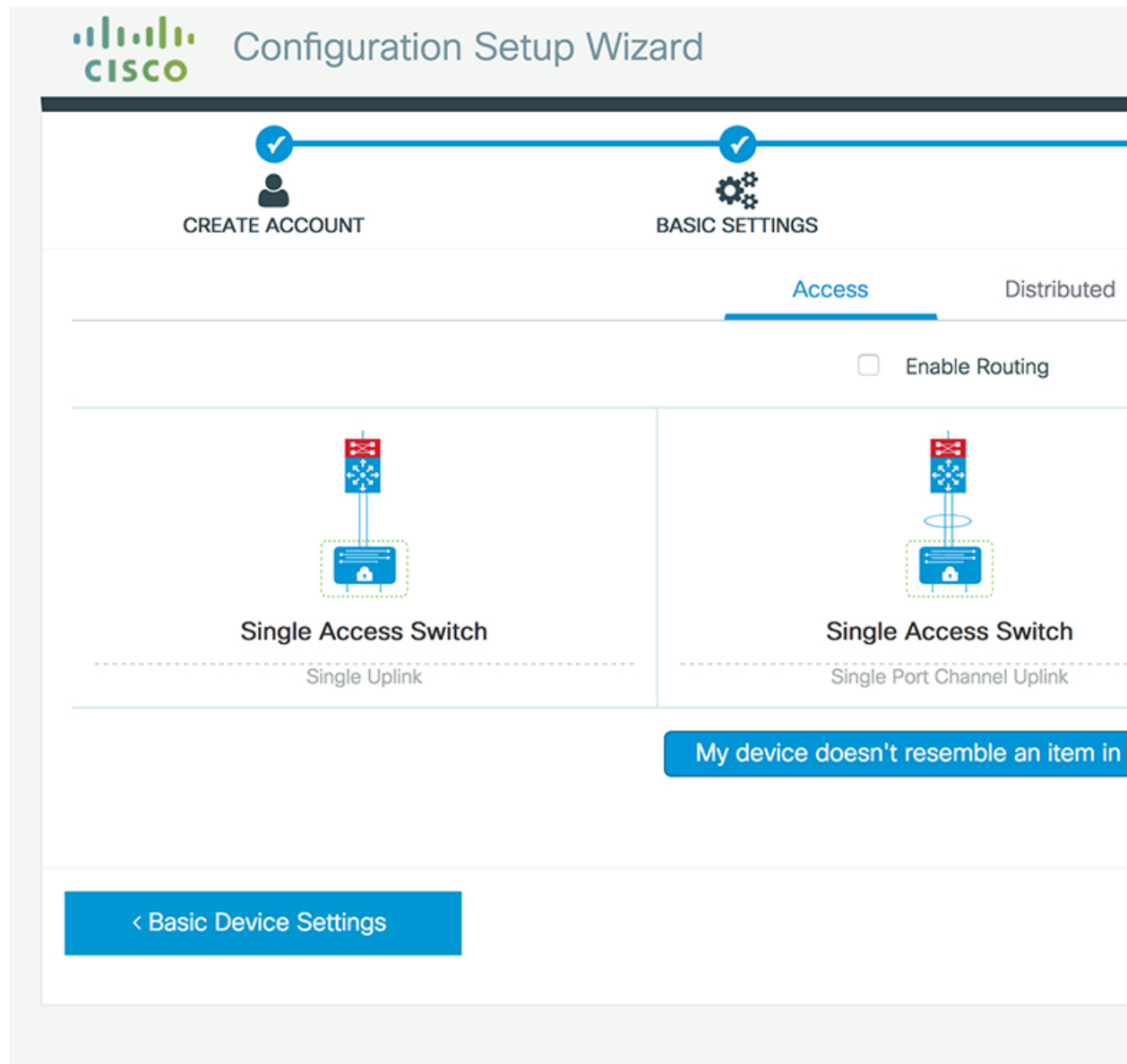


Figure 76: Site Profile - Access Switches (with Routed Access)

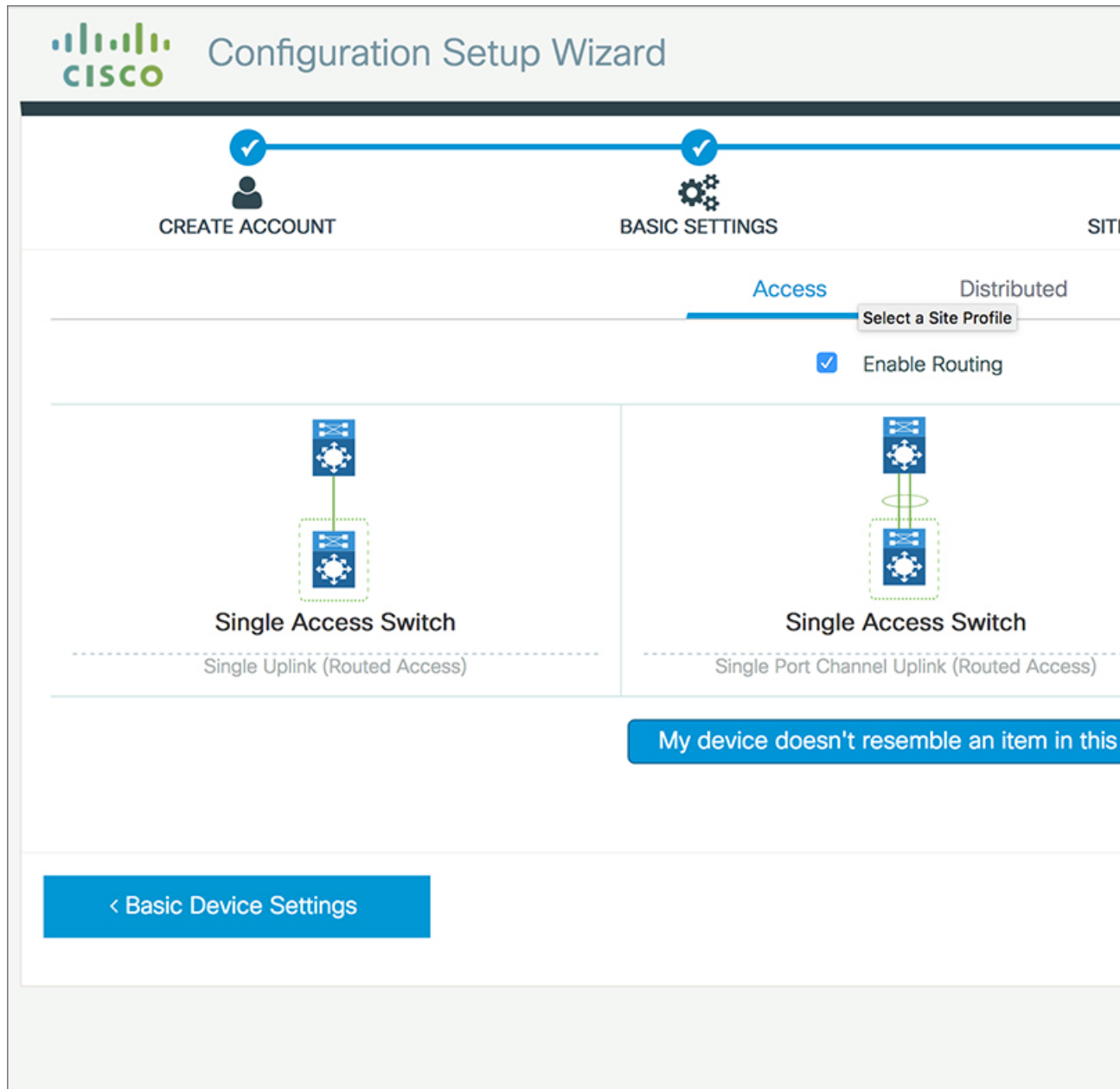


Table 29: Default Configuration Loaded with Each Site Profile (Distribution Switches)

Setting	Single Distribution Switch (Single Downlink)	Single Distribution Switch (Single Port Channel Downlink)	Redundant Distribution Switch (Port Channel Peer and Downlink)
Hostname	The hostname or device name you provided as part of Quick Setup	The hostname or device name you provided as part of Quick Setup	The hostname or device name you provided as part of Quick Setup

Setting	Single Distribution Switch (Single Downlink)	Single Distribution Switch (Single Port Channel Downlink)	Redundant Distribution Switch (Port Channel Peer and Downlink)
Spanning Tree Mode	RPVST+	RPVST+	RPVST+
VTP	Mode Transparent	Mode Transparent	Mode Transparent
UDLD	Enabled	Enabled	Enabled
Error Disable Recovery	Recovery mode set to Auto	Recovery mode set to Auto	Recovery mode set to Auto
Port Channel Load Balance	Source Destination IP	Source Destination IP	Source Destination IP
SSH	Version 2	Version 2	Version 2
SCP	Enabled	Enabled	Enabled
VTY Access to Switch	Enabled	Enabled	Enabled
Service Timestamp	Enabled	Enabled	Enabled
VLAN	The following VLANs are created: <ul style="list-style-type: none"> <li>• Default VLAN</li> <li>• Data VLAN</li> <li>• Voice VLAN</li> <li>• Management VLAN</li> </ul>	The following VLANs are created: <ul style="list-style-type: none"> <li>• Default VLAN</li> <li>• Data VLAN</li> <li>• Voice VLAN</li> <li>• Management VLAN</li> </ul>	The following VLANs are created: <ul style="list-style-type: none"> <li>• Default VLAN</li> <li>• Data VLAN</li> <li>• Voice VLAN</li> <li>• Management VLAN</li> </ul>
Management Interface	Layer 3 settings configured on the management port, based on Quick Setup	Layer 3 settings configured on the management port, based on Quick Setup	Layer 3 settings configured on the management port, based on Quick Setup
QoS Policy	QoS Policy for Distribution defined	QoS Policy for Distribution defined	QoS Policy for Distribution defined
Uplink Interfaces	Selected uplink ports connect to other distribution or core switches	Selected uplink ports connect to other distribution or core switches	Selected uplink ports connect to other distribution or core switches
Downlink Interfaces	Downlink connections to access switches configured in Trunk mode	Downlink connections to access switches configured in Trunk mode	Downlink connections to access switches configured in Trunk mode
Port-channel	Port-channel to core created	Port-channel to core or access created	Port-channel to core or distribution created

Figure 77: Site Profile - Distribution Switches

The screenshot shows the Cisco Configuration Setup Wizard interface. At the top, the Cisco logo and the title "Configuration Setup Wizard" are visible. Below the logo, a progress bar indicates the current step: "CREATE ACCOUNT" (completed) and "BASIC SETTINGS" (current step). The "Distributed" tab is selected under the "Access" section. An "Enable Routing" checkbox is present and unchecked. Two switch configuration options are shown: "Single Distribution Switch" with a "Single Downlink" and "Single Distribution Switch" with a "Single Port Channel Downlink". A blue button at the bottom left is labeled "< Basic Device Settings". A blue banner at the bottom right contains the text "My device doesn't resemble an item in this".

Figure 78: Site Profile - Distribution Switches (with Routed Access)

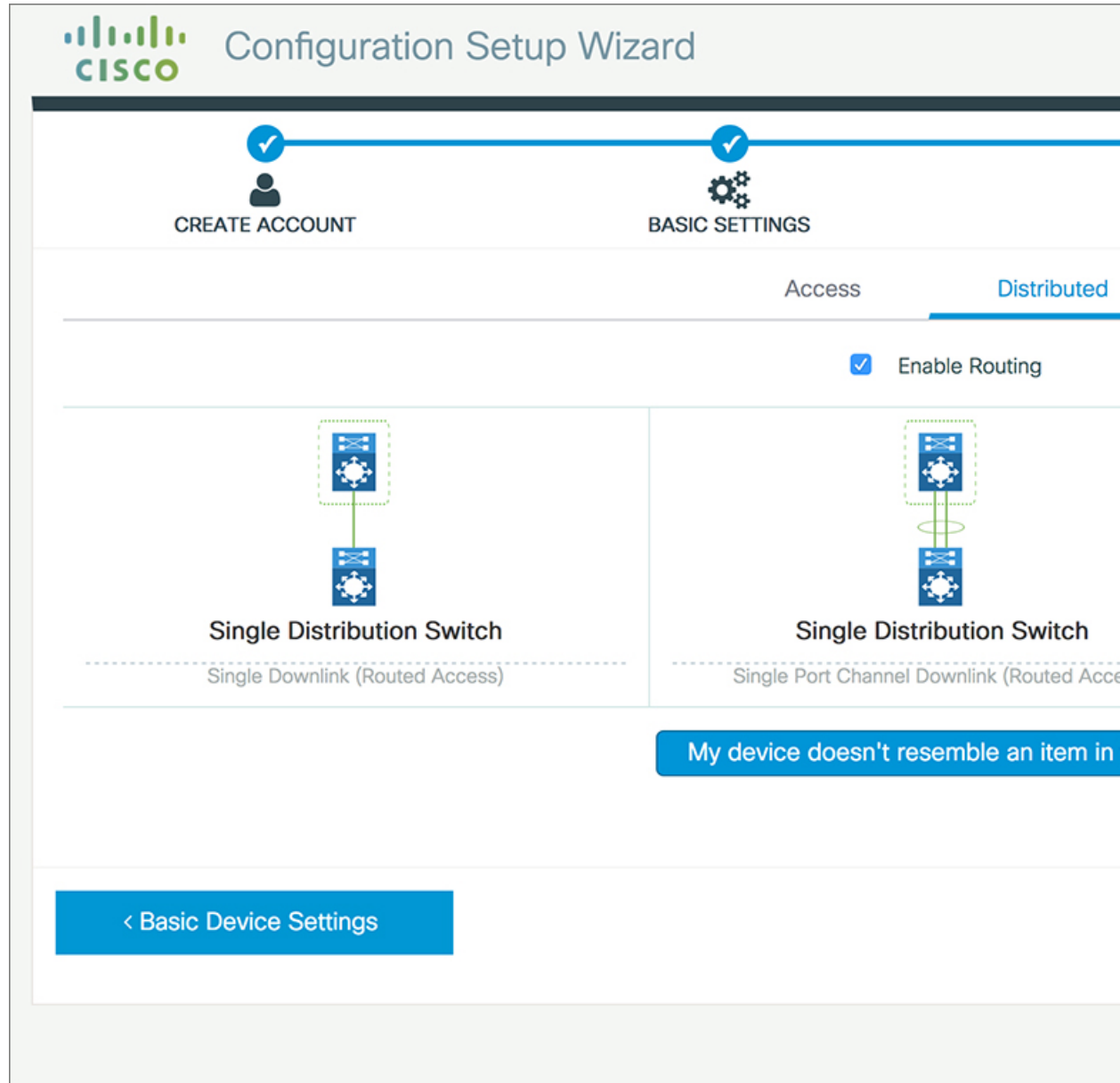
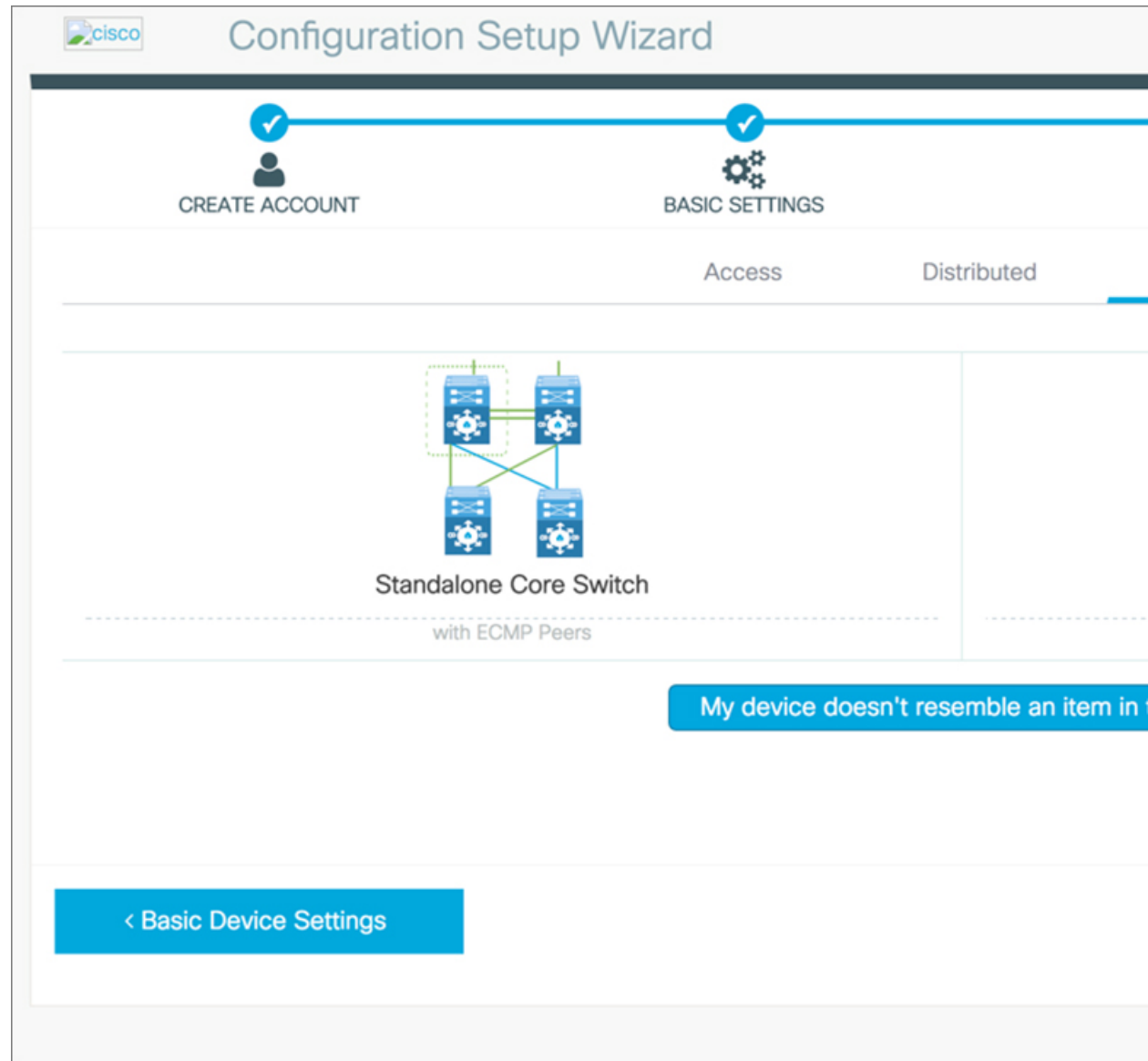


Table 30: Default Configuration Loaded with Each Site Profile (Core Switches)

Setting	Standalone Core Switch (with ECMP Peers)	Standalone Collapsed Core Switch (with ECMP Peer and Port Channel Downlink)
Hostname	The hostname or device name you provided as part of Quick Setup	The hostname or device name you provided as part of Quick Setup
UDLD	Enabled	Enabled

Setting	Standalone Core Switch (with ECMP Peers)	Standalone Collapsed Core Switch (with ECMP Peer and Port Channel Downlink)
Error Disable Recovery	Recovery mode set to Auto	Recovery mode set to Auto
Port Channel Load Balance	Source Destination IP	Source Destination IP
SSH	Version 2	Version 2
SCP	Enabled	Enabled
VTY Access to Switch	Enabled	Enabled
Mitigate Address Spoofing	Unicast RPF (uRPF) in strict mode	Unicast RPF (uRPF) in strict mode
Service Timestamp	Enabled	Enabled
Management Interface	Layer 3 settings configured on the management port, based on Quick Setup	Layer 3 settings configured on the management port, based on Quick Setup
QoS Policy	QoS Policy for Distribution/Core defined	QoS Policy for Distribution/Core defined
Uplink Interfaces	Selected uplink ports connect to MAN/WAN device	Selected uplink ports connect to MAN/WAN device
Downlink Interfaces	Downlink connections to access switches	Downlink connections to distribution switches
Cross-connect Interfaces	Selected ports connect to other core switches	Selected ports connect to other core switches

Figure 79: Site Profile - Core Switches



## Configuring Switch Wide Settings

### Configuring VLAN Settings

#### Procedure

- Step 1** In the **VLAN Configuration** section, you can configure both data and voice VLANs. Type a name for your data VLAN.

- Step 2** To configure a data VLAN, ensure that the **Data VLAN** check box is checked, type a name for your VLAN, and assign a VLAN ID to it. If you are creating several VLANs, indicate only a VLAN range.
- Step 3** To configure a voice VLAN, ensure that the **Voice VLAN** check box is checked, type a name for your VLAN, and assign a VLAN ID to it. If you are creating several VLANs, indicate a VLAN range.
- 

## Configure STP Settings

### Procedure

---

- Step 1** RPVST is the default STP mode configured on your device. You can change it to PVST from the **STP Mode** drop-down list.
- Step 2** To change a bridge priority number from the default value 32748, change **Bridge Priority** to Yes and choose a priority number from the drop-down list.

Figure 80: VLAN and STP Settings

The screenshot shows the Cisco Configuration Setup Wizard interface. At the top, the Cisco logo and the title "Configuration Setup Wizard" are visible. Below the title, a progress bar indicates two completed steps: "CREATE ACCOUNT" and "BASIC SETTINGS". The main content area is divided into three sections:

- VLAN Configuration:** This section contains three radio button options: "Data VLAN", "Voice VLAN", and "Management VLAN". A tooltip labeled "Switch Wide Settings" is visible over the "Management VLAN" option.
- STP Configuration:** This section includes:
  - "STP Mode" set to "RPVST" in a text input field.
  - "Bridge Priority" checked with a blue checkmark.
  - "Bridge Priority Number" set to "32768" in a text input field.
- General Configuration:** This section contains a blue button labeled "< Site Profile".

## Configuring DHCP, NTP, DNS and SNMP Settings

### Procedure

- Step 1** In the **Domain Details** section, enter a domain name that the software uses to complete unqualified hostnames.
- Step 2** Type an IP address to identify the DNS server. This server is used for name and address resolution on your device.

- Step 3** In the **Server Details** section, type the IP address of the DNS server that you want to make available to DHCP clients.
- Step 4** In the **Syslog Server** field, type the IP address of the server to which you want to send syslog messages.
- Step 5** To ensure that your device is configured with the right time, date and timezone, enter the IP address of the NTP server with which you want to synchronize the device time.
- Step 6** In the **Management Details** section, type an IP address to identify the SNMP server. SNMPv1, SNMPv2, and SNMPv3 are supported on your device.
- Step 7** Specify the **SNMP community** string to permit access to the SNMP protocol.

*Figure 81: DHCP, NTP, DNS and SNMP Settings*

The screenshot displays the Cisco Configuration Setup Wizard interface. At the top, the Cisco logo and the title 'Configuration Setup Wizard' are visible. A progress bar shows two steps: 'CREATE ACCOUNT' (completed with a checkmark) and 'BASIC SETTINGS' (current step, also with a checkmark). Below the progress bar, the 'General Configuration' section is active. It contains three sub-sections: 'Domain Details' with fields for 'Domain Name' and 'DNS Server'; 'Server Details' with fields for 'DHCP Server', 'Syslog Server', and 'NTP Server'; and 'Management Details'. A blue button labeled '< Site Profile' is located at the bottom left of the configuration area.

**What to do next**

Configure port settings.

## Configuring Port Settings

**Procedure**

---

- Step 1** Based on the site profile chosen in the earlier step which is displayed in the left-pane, select the **Port Role** from among the following options:
- Uplink – For connecting to devices towards the core of the network.
  - Downlink – For connecting to devices further down in the network topology.
  - Access – For connecting guest devices that are VLAN-unaware.
- Step 2** Choose an option from the **Select Switch** drop-down list.
- Step 3** Make selections from the **Available** list of interfaces based on how you want to enable them and move them to the **Enabled** list.

Figure 82: Port Settings

**CISCO** Configuration Setup Wizard

CREATE ACCOUNT BASIC SETTINGS

Port Role  Uplink  Access

Select Switch ALL

Available (16)

Uplinks

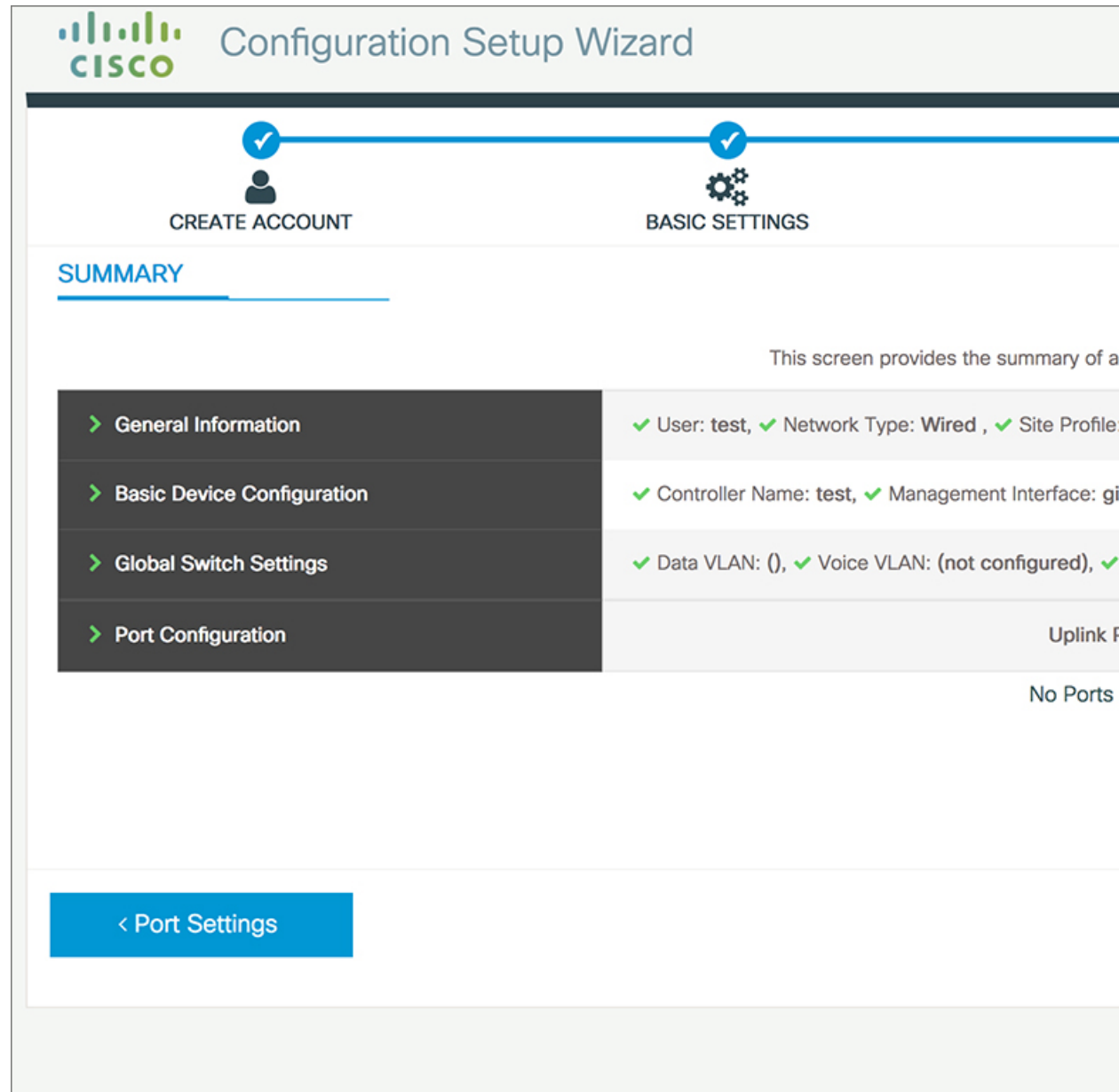
- GigabitEthernet1/1/1
- GigabitEthernet1/1/2
- GigabitEthernet1/1/3
- GigabitEthernet1/1/4

< Switch Wide Settings

**What to do next**

- Click **Day 0 Config Summary** to verify your setup.
- Click **Finish**.

Figure 83: Day 0 Config Summary



## Configuring the Switch Using the CLI

### Accessing the CLI Through the Console Port

You can access the CLI on a configured or unconfigured switch by connecting the RJ-45 console port or USB console port of the switch to your PC or workstation and accessing the switch through a terminal emulation program.



---

**Note** If you have stacked your switches, connect to the console port of one of the switches in the stack. You can initially configure the entire stack from any member switch.

---

## Connecting the RJ-45 Console Port

### Procedure

---

- Step 1** Connect the RJ-45-to-DB-9 adapter cable to the 9-pin serial port on the PC. Connect the other end of the cable to the switch console port.
- Step 2** Start the terminal-emulation program on the PC or the terminal. The program, frequently a PC application such as HyperTerminal or ProcommPlus, makes communication between the switch and your PC or terminal possible.
- Step 3** Configure the baud rate and character format of the PC or terminal to match the console port default characteristics:
- 9600 baud
  - 8 data bits
  - 1 stop bit
  - No parity
  - None (flow control)
- Step 4** Power on the switch as described in the switch getting started guide.
- Step 5** The PC or terminal displays the bootloader sequence. Press **Enter** to display the setup prompt.
- 

## Connecting the USB Console Port

### Procedure

---

- Step 1** If you are connecting the switch USB console port to a Windows-based PC for the first time, install the USB driver. See [Installing the Cisco Microsoft Windows USB Device Driver, on page 111](#).

**Note** USB Type A port on the switch provides file system support and is **NOT** a console port. See USB Type A Port section.

Figure 84: Connecting the USB Console Cable to the Switch

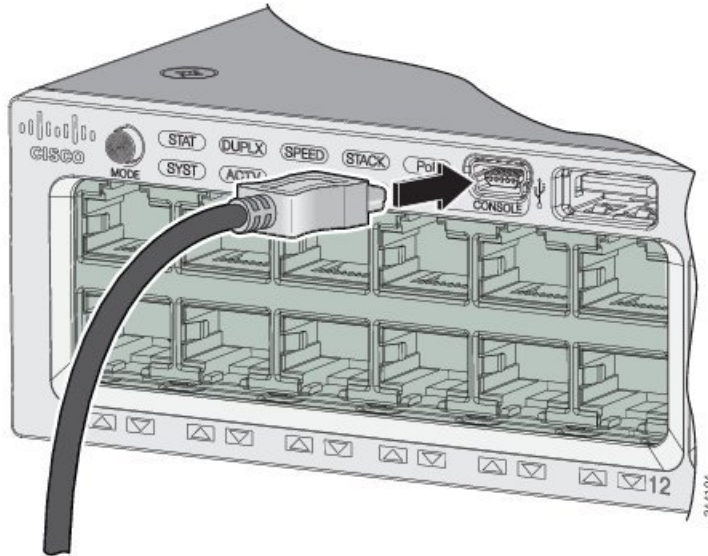
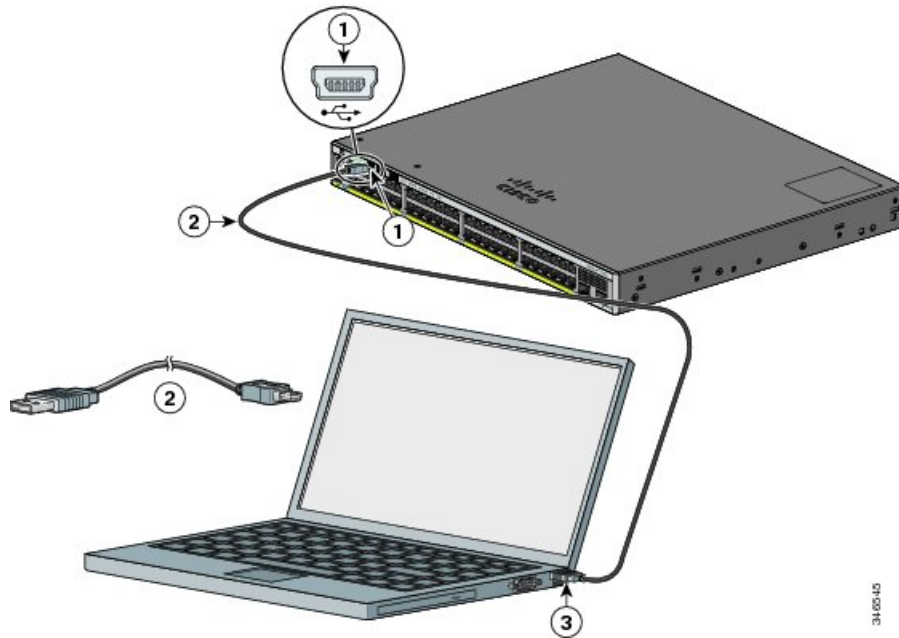
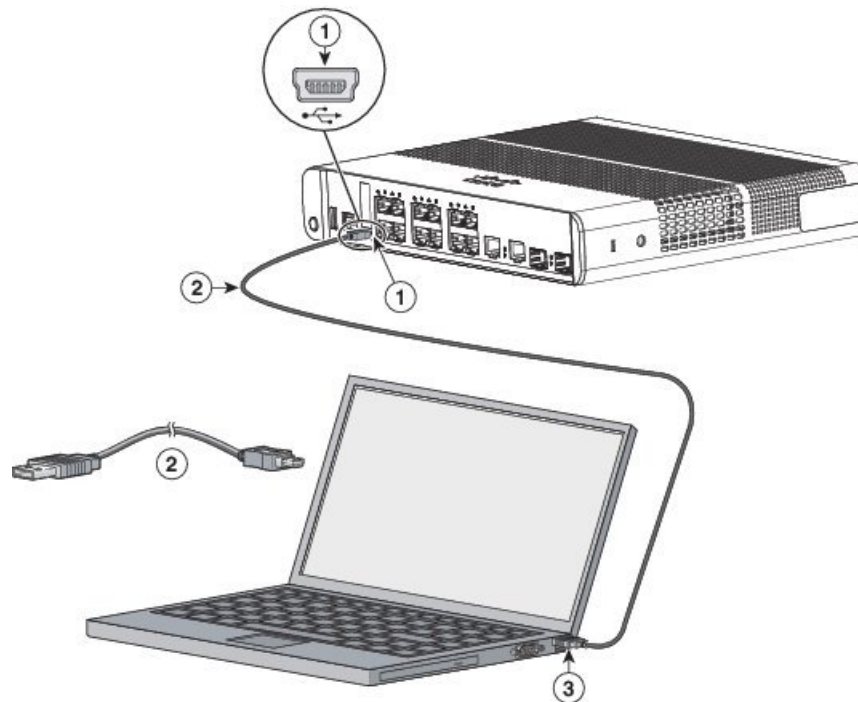


Figure 85: Connecting the USB Console Cable to the Switch





1	USB console port (5-pin mini-Type B)	3	USB Type A connection on the laptop
2	USB Type A to 5-pin mini-Type B cable		

- Step 2** Connect a USB cable to the PC USB port. Connect the other end of the cable to the switch mini-B (5-pin-connector) USB console port.
- Step 3** Start the terminal-emulation program on the PC or the terminal. The program, frequently a PC application such as HyperTerminal or ProcommPlus, makes communication between the switch and your PC or terminal possible.
- Step 4** Configure the baud rate and character format of the PC or terminal to match the console port default characteristics:
- 9600 baud
  - 8 data bits
  - 1 stop bit
  - No parity
  - None (flow control)
- Step 5** Power on the switch as described in the switch getting started guide.
- Step 6** The PC or terminal displays the bootloader sequence. Press **Enter** to display the setup prompt. Follow the steps in the Setup program.

## Installing the Cisco Microsoft Windows USB Device Driver

A USB device driver must be installed the first time a Microsoft Windows-based PC is connected to the USB console port on the switch.

- [Installing the Cisco Microsoft Windows XP USB Driver](#)
- [Installing the Cisco Microsoft Windows 2000 USB Driver](#)
- [Installing the Cisco Microsoft Windows Vista and Windows 7 USB Driver](#)

### Installing the Cisco Microsoft Windows XP USB Driver

#### Procedure

---

- Step 1** Obtain the Cisco USB console driver file from the Cisco.com web site and unzip it.
- Note** You can download the driver file from the Cisco.com site for downloading the switch software.
- Step 2** If using 32-bit Windows XP, double-click the setup.exe file in the Windows\_32 folder. If using 64-bit Windows XP, double-click the setup(x64).exe file in the Windows\_64 folder.
- Step 3** The Cisco Virtual Com InstallShield Wizard begins.
- Step 4** The Ready to Install the Program window appears. Click **Install**.
- Step 5** The InstallShield Wizard Completed window appears. Click **Finish**.
- Step 6** Connect the USB cable to the PC and the switch console port. The USB console port LED turns green, and the Found New Hardware Wizard appears. Follow the instructions to complete the driver installation.
- 

### Installing the Cisco Microsoft Windows 2000 USB Driver

#### Procedure

---

- Step 1** Obtain the Cisco USB console driver file from the Cisco.com web site and unzip it.
- Note** You can download the driver file from the Cisco.com site for downloading the switch software.
- Step 2** Double-click the setup.exe file.
- Step 3** The Cisco Virtual Com InstallShield Wizard begins. Click **Next**.
- Step 4** The Ready to Install the Program window appears. Click **Install**.
- Step 5** The InstallShield Wizard Completed window appears. Click **Finish**.
- Step 6** Connect the USB cable to the PC and the switch console port. The USB console port LED turns green, and the Found New Hardware Wizard appears. Follow the instructions to complete the driver installation.
-

## Installing the Cisco Microsoft Windows Vista and Windows 7 USB Driver

### Procedure

---

- Step 1** Obtain the Cisco USB console driver file from the Cisco.com web site and unzip it.
- Note** You can download the driver file from the Cisco.com site for downloading the switch software.
- Step 2** If using 32-bit Windows Vista or Windows 7, double-click the setup.exe file in the Windows\_32 folder. If using 64-bit Windows Vista or Windows 7, double-click the setup(x64).exe file in the Windows\_64 folder.
- Step 3** The Cisco Virtual Com InstallShield Wizard begins. Click **Next**.
- Step 4** The Ready to Install the Program window appears. Click **Install**.
- Note** If a User Account Control warning appears, click **Allow - I trust this program** to proceed.
- Step 5** The InstallShield Wizard Completed window appears. Click **Finish**.
- Step 6** Connect the USB cable to the PC and the switch console port. The USB console port LED turns green, and the Found New Hardware Wizard appears. Follow the instructions to complete the driver installation.
- 

## Uninstalling the Cisco Microsoft Windows USB Driver

### Uninstalling the Cisco Microsoft Windows XP and 2000 USB Driver

Use the Windows Add or Remove Programs utility or the setup.exe file.

#### Using the Setup.exe Program

##### Before you begin

Disconnect the switch console terminal before uninstalling the driver.

##### Procedure

---

- Step 1** Run setup.exe for Windows 32-bit or setup(x64).exe for Windows-64bit. Click **Next**.
- Step 2** The InstallShield Wizard for Cisco Virtual Com appears. Click **Next**.
- Step 3** When the Program Maintenance window appears, select the Remove radio button. Click **Next**.
- Step 4** When the Remove the Program window appears, click **Remove**.
- Step 5** When the InstallShield Wizard Completed window appears, click **Finish**.
- 

#### Using the Add or Remove Programs Utility

##### Before you begin

Disconnect the switch console terminal before uninstalling the driver.

---

**Procedure**

---

- Step 1** Click **Start > Control Panel > Add or Remove Programs**.
- Step 2** Scroll to Cisco Virtual Com and click **Remove**.
- Step 3** When the Program Maintenance window appears, select the **Remove** radio button. Click **Next**.
- 

## Uninstalling the Cisco Microsoft Windows Vista and Windows 7 USB Driver

**Before you begin**

Disconnect the switch console terminal before uninstalling the driver.

**Procedure**

---

- Step 1** Run setup.exe for Windows 32-bit or setup(x64).exe for Windows-64bit. Click **Next**.
- Step 2** The InstallShield Wizard for Cisco Virtual Com appears. Click **Next**.
- Step 3** When the Program Maintenance window appears, select the Remove radio button. Click **Next**.
- Step 4** When the Remove the Program window appears, click **Remove**.
- Note** If a User Account Control warning appears, click **Allow - I trust this program to proceed**.
- Step 5** When the InstallShield Wizard Completed window appears, click **Finish**.
-





## CHAPTER 7

# Troubleshooting

---

- [Diagnosing Problems, on page 115](#)
- [Replacing a Failed Data Stack Member, on page 119](#)

## Diagnosing Problems

The LEDs on the front panel provide troubleshooting information about the switch. They show POST failures, port-connectivity problems, and overall switch performance. You can also get statistics from Device Manager, from the CLI, or from an SNMP workstation.

## Switch POST Results

POST failures are usually fatal. Contact your Cisco technical support representative if your switch does not pass POST.

## Switch LEDs

If you have physical access to the switch, look at the port LEDs for troubleshooting information about the switch. See the LED section for a description of the LED colors and their meanings.

## Switch Connections

### Bad or Damaged Cable

Always examine the cable for marginal damage or failure. A cable might be just good enough to connect at the physical layer, but it could corrupt packets as a result of subtle damage to the wiring or connectors. You can identify this situation because the port has many packet errors or the port constantly flaps (loses and regains link).

- Examine or exchange the copper or fiber-optic cable with a known, good cable.
- Look for broken or missing pins on cable connectors.
- Rule out any bad patch panel connections or media converters between the source and the destination. If possible, bypass the patch panel, or eliminate faulty media converters (fiber-optic-to-copper).
- Try the cable in another port or interface, if possible, to see if the problem follows the cable.

- Remove and inspect the stack cable and stack port for bent pins or damaged connectors. If the cable is bad, replace it with a known good cable.

## Ethernet and Fiber-Optic Cables

Make sure that you have the correct cable for the connection.

- For Ethernet, use Category 3 copper cable for 10 Mb/s UTP connections. Use either Category 5, Category 5e, or Category 6 UTP for 10/100/1000 Mb/s connections.
- For fiber-optic cables, verify that you have the correct cable for distance and port type. Ensure that the connected device ports match and use the same type of encoding, optical frequency, and fiber type.
- For copper connections, determine if a crossover cable was used when a straight-through was required or the reverse. Enable auto-MDIX on the switch, or replace the cable.

## Link Status

Verify that both sides have link. A single broken wire or a shutdown port can cause one side to show link even though the other side does not have link.

A port LED that is on does not guarantee that the cable is fully functional. The cable might have encountered physical stress that causes it to function at a marginal level. If the port LED does not turn on:

- Connect the cable from the switch to a known good device.
- Ensure that both ends of the cable are connected to the correct ports.
- Verify that both devices have power.
- Verify that you are using the correct cable type.
- Check for loose connections. Sometimes a cable appears to be seated, but is not. Disconnect the cable and then reconnect it.

## 10/100/1000 Port Connections

A port appears to malfunction:

- Use the Mode button to show the status for all ports.
- Use the **show interfaces** privileged EXEC command to see if the port is error-disabled, disabled, or shutdown. Reenable the port if necessary.

## 10/100/1000 PoE+ Port Connections

A powered device connected to a PoE port does not receive power:

- Use the Mode button to show the PoE status for all ports.
- Use the **show interfaces** privileged EXEC command to see if the port is in error-disabled, disabled, or shutdown. Reenable the port if necessary.
- Verify that the power supply installed in the switch meets the power requirements of your connected devices.

- Verify that there is sufficient PoE power budget to provide power to the attached device. Use the **show power inline** global configuration command to check on the available PoE power budget.
- Verify the cable type. Many legacy powered devices, including older Cisco IP phones and access points that do not fully support IEEE 802.3af, might not support PoE when connected to the switch by a crossover cable. Replace the crossover cable with a straight-through cable.



---

**Caution** Noncompliant cabling or powered devices can cause a PoE port fault. Use only standard-compliant cabling to connect Cisco prestandard IP Phones and wireless access points or IEEE 802.3af-compliant devices. You must remove any cable or device that causes a PoE fault.

---

## SFP and SFP+ Module

Use only Cisco SFP or SFP+ modules in the switch. Each Cisco module has an internal serial EEPROM that is encoded with security information. This encoding provides a way for Cisco to identify and validate that the module meets the requirements for the switch.

- Inspect the SFP module. Exchange the suspect module with a known good module. Verify that the module is supported on this platform. (The switch release notes on Cisco.com list the SFP modules that the switch supports.)
- Use the **show interfaces** privileged EXEC command to see if the port or module is error-disabled, disabled, or shutdown. Reenable the port if needed.
- Make sure that all fiber-optic connections are properly cleaned and securely connected.
- When you insert several SFPs in multiple switch ports, wait for 5 seconds between inserting each SFP. This will prevent the ports from going into error disabled mode. Similarly, when you remove an SFP from a port, wait for 5 seconds before reinserting it.

## Interface Settings

Verify that the interface is not disabled or powered off. If an interface is manually shut down on either side of the link, it does not come up until you reenable the interface. Use the **show interfaces** privileged EXEC command to see if the interface is error-disabled, disabled, or shutdown on either side of the connection. If needed, reenable the interface.

## Ping End Device

Ping from the directly connected switch first, and then work your way back port by port, interface by interface, trunk by trunk, until you find the source of the connectivity issue. Make sure that each switch can identify the end device MAC address in its Content-Addressable Memory (CAM) table.

## Spanning Tree Loops

STP loops can cause serious performance issues that look like port or interface problems.

A unidirectional link can cause loops. It occurs when the traffic sent by the switch is received by its neighbor, but the traffic from the neighbor is not received by the switch. A broken fiber-optic cable, other cabling problems, or a port issue could cause this one-way communication.

You can enable UniDirectional Link Detection (UDLD) on the switch to help identify unidirectional link problems.

## Switch Performance

### Speed, Duplex, and Autonegotiation

If the port statistics show a large amount of alignment errors, frame check sequence (FCS), or late-collisions errors, this might mean a speed or duplex mismatch.

A common issue with speed and duplex occurs when duplex and speed settings are mismatched between two switches, between a switch and a router, or between the switch and a workstation or server. Mismatches can happen when manually setting the speed and duplex or from autonegotiation issues between the two devices.

To maximize switch performance and to ensure a link, follow one of these guidelines when changing the duplex or the speed settings.

- Let both ports autonegotiate both speed and duplex.
- Manually set the speed and duplex parameters for the interfaces on both ends of the connection.
- If a remote device does not autonegotiate, use the same duplex settings on the two ports. The speed parameter adjusts itself even if the connected port does not autonegotiate.

### Autonegotiation and Network Interface Cards

Problems sometimes occur between the switch and third-party network interface cards (NICs). By default, the switch ports and interfaces autonegotiate. Laptops or other devices are commonly set to autonegotiate, yet sometimes autonegotiation issues occur.

To troubleshoot autonegotiation problems, try manually setting both sides of the connection. If this does not solve the problem, there could be a problem with the firmware or software on your NIC. You can resolve this by upgrading the NIC driver to the latest version.

### Cabling Distance

If the port statistics show excessive FCS, late-collision, or alignment errors, verify that the cable distance from the switch to the connected device meets the recommended guidelines.

## Clearing the Switch IP Address and Configuration

If you have configured a new switch with a wrong IP address, or if all of the switch LEDs start blinking when you are trying to enter Express Setup mode, you can clear the configured IP address. The switch returns to the factory default settings.

**Note**

This procedure clears the IP address and all configuration information stored on the switch. Do not follow this procedure unless you want to completely reconfigure the switch.

### Procedure

---

- Step 1** If you are using Cisco IOS XE Release 3E or later releases, enter the **erase startup-config** privileged EXEC command to clear the contents of your startup configuration.
- Step 2** Press and hold the **Mode** button. The switch LEDs blink after about 2 seconds. If the switch is not configured, the LEDs above the Mode button turn green. You can omit the next step.
- Step 3** Continue holding down the Mode button. The LEDs stop blinking after 8 seconds, and then the switch reboots. You can now configure the switch by using Express Setup as described in the switch getting started guide. You can also configure the switch by using the CLI setup procedure described in the appendix.
- 

## Replacing a Failed Data Stack Member

### Procedure

---

- Step 1** The replacement switch must be a Catalyst 3850 switch.
- Step 2** Power down the failed switch. Remove AC or DC input power, and if the switch is part of a StackPower stack, remove the StackPower cables.
- Step 3** Make sure the replacement switch is powered off, and then connect it to the stack. If you had manually set the member numbers for the switch stack, manually assign the member number of the failed switch to the replacement switch. To manually assign the stack member number, see the switch software configuration guide on Cisco.com.
- Step 4** Make the same Gigabit Ethernet connections on the replacement switch that were on the failed switch.
- Step 5** Reinstall any modules, and make cable connections.
- Step 6** Power on the replacement switch.

The replacement switch has the same configuration for all the interfaces as the failed switch and functions the same as the failed switch.

---





# APPENDIX **A**

## Technical Specifications

- [Environmental and Physical Specifications, on page 121](#)
- [Specifications for the Power Supplies, Switches, and Fan, on page 123](#)

### Environmental and Physical Specifications

This table describes the environmental specifications.

**Table 31: Environmental Specifications for the Switch**

Environmental Ranges	
Operating temperature <a href="#">14</a>	23 to 113°F (–5 to 45°C)
Storage temperature	–40 to 158°F (–40 to 70°C)
Relative humidity	5 to 95% (noncondensing)
Operating altitude	Up to 10,000 ft (3000 m)
Storage altitude	Up to 15,000 ft (4500 m)

<sup>14</sup> Minimum ambient temperature for cold start is 32°F (0°C)

This table describes the environmental specifications.

**Table 32: Environmental Specifications for the Power Supplies**

Environmental Ranges	
Operating temperature	AC power supply: 23 to 113°F (–5 to 45°C) DC power supply: 23 to 131°F (–5 to 55°C)
Storage temperature	–40 to 158°F (–40 to 70°C)
Relative humidity	10 to 95% (noncondensing)

Environmental Ranges	
Altitude	AC power supply: up to 10,000 ft (3,000 m) DC power supply: up to 13,000 ft (4,000 m)

This table describes the physical specifications.

**Table 33: Physical Specifications for the Switch**

Physical Specifications	
Dimensions (H x W x D)	1.73 x 17.5 x 17.5 in. (4.4 x 44.5 x 44.5 cm) (with the FAN FRUs installed but without the power supplies installed)
Weight (weights do not include the functional network modules, the blank module, or the power supplies).	
Catalyst 3850 24-port PoE switches	13.3 lb (6.0 kg)
Catalyst 3850 24-port non-PoE switches	13.1 lb (6.0 kg)
Catalyst 3850 48-port non-PoE switches	14.2 lb (6.5 kg)
Catalyst 3850 48-port PoE switches	14.4 lb (6.5 kg)
WS-C3850-24S and WS-C3850-12S switches	12.4 lb (5.7 kg)
WS-C3850-12XS switches	12.9 lb (5.8 kg)
WS-C3850-24XS switches	13.5 lb (6.1 kg)
WS-C3850-48XS switches	16.42 lb (7.45 kg)

This table describes the physical specifications.

**Table 34: Physical Specifications for the Power Supplies**

Weight	
PWR-C1-1100WAC	3 lb (1.4 kg)
PWR-C1-715WAC	2.8 lb (1.3 kg)
PWR-C1-350WAC	2.4 lb (1.1 kg)
PWR-C1-440WDC=	2.6 lb (1.2 kg)
PWR-C3-750WAC-R	3.7 lb (1.68 kg)
PWR-C3-750WAC-F	3.7 lb (1.68 kg)
PWR-C3-750WDC-R	3.7 lb (1.68 kg)
PWR-C3-750WDC-F	3.7 lb (1.68 kg)

<b>Dimensions (H x D x W)</b>	
The dimensions shown include the extraction handle and the keying feature.	
PWR-C1-1100WAC	1.58 X 3.25 X 13.71 in. (40.1 X 82.55 X 348.2 mm)
PWR-C1-715WAC	1.58 X 3.25 X 12.21 in. (40.1 X 82.55 X 310.1 mm)
PWR-C1-350WAC	1.58 X 3.25 X 12.21 in. (40.1 X 82.55 X 310.1 mm)
PWR-C1-440WDC=	1.58 X 3.25 X 12.21 in. (40.1 X 82.55 X 310.1 mm)
PWR-C3-750WAC-R	1.58 X 2.15 X 14.28 in. (40.1 mm X 54.6 mm X 362.7 mm)
PWR-C3-750WAC-F	1.58 X 2.15 X 14.28 in. (40.1 mm X 54.6 mm X 362.7 mm)
PWR-C3-750WDC-R	1.58 X 2.15 X 14.28 in. (40.1 mm X 54.6 mm X 362.7 mm)
PWR-C3-750WDC-F	1.58 X 2.15 X 14.28 in. (40.1 mm X 54.6 mm X 362.7 mm)

## Specifications for the Power Supplies, Switches, and Fan

*Table 35: Power Specifications for the AC Power*

<b>Power Requirements</b>	
Maximum output power	<ul style="list-style-type: none"> <li>• PWR-C1-1100WAC: 1100 W</li> <li>• PWR-C1-715WAC: 715 W</li> <li>• PWR-C1-350WAC: 350 W</li> <li>• PWR-C3-750WAC-R: 750 W</li> <li>• PWR-C3-750WAC-F: 750 W</li> </ul>
Input voltage and Frequency	<ul style="list-style-type: none"> <li>• PWR-C1-1100WAC: 1100-W, 115 to 240 VAC (autoranging) 50-60 Hz</li> <li>• PWR-C1-715WAC: 715 W, 100 to 240 VAC (autoranging) 50-60 Hz</li> <li>• PWR-C1-350WAC: 350 W, 100 to 240 VAC (autoranging) 50-60 Hz</li> <li>• PWR-C3-750WAC-F: 750 W, 90 to 264 VAC (autoranging) 50-60 Hz</li> <li>• PWR-C3-750WAC-F: 750 W, 90 to 264 VAC (autoranging) 50-60 Hz</li> </ul>

Input current	<ul style="list-style-type: none"> <li>• PWR-C1-1100WAC: 12–6 A</li> <li>• PWR-C1-715WAC: 10–5 A</li> <li>• PWR-C1-350WAC: 4–2 A</li> <li>• PWR-C3-750WAC-R: 11 A @ 100 VAC (max), 6 A @ 200 VAC (max)</li> <li>• PWR-C3-750WAC-F: 11 A @ 100 VAC (max), 6 A @ 200 VAC (max)</li> </ul>
Output ratings	<ul style="list-style-type: none"> <li>• PWR-C1-1100WAC: –56 V@19.64 A</li> <li>• PWR-C1-715WAC: –56 V@12.8 A</li> <li>• PWR-C1-350WAC: –56 V@6.25 A</li> <li>• PWR-C3-750WAC-R: 12 VDC @ 62 A, 3.3 VDC @ 3 A</li> <li>• PWR-C3-750WAC-F: 12 VDC @ 62 A, 3.3 VDC @ 3 A</li> </ul>
Total input BTU <sup>15</sup>	<ul style="list-style-type: none"> <li>• PWR-C1-1100WAC: 4263 BTUs per hour, 1250 W</li> <li>• PWR-C1-715WAC: 2742 BTUs per hour, 804 W</li> <li>• PWR-C1-350WAC: 1357 BTUs per hour, 398 W</li> </ul>
Total output BTU <sup>16</sup>	<ul style="list-style-type: none"> <li>• PWR-C1-1100WAC: 3751 BTUs per hour, 1100 W</li> <li>• PWR-C1-715WAC: 2438 BTUs per hour, 715 W</li> <li>• PWR-C1-350WAC: 1194 BTUs per hour, 350 W</li> <li>• PWR-C3-750WAC-R: 1122 BTU/hour (nominal), 1365 BTU/hour (max)</li> <li>• PWR-C3-750WAC-F: 1122 BTU/hour (nominal), 1365 BTU/hour (max)</li> </ul>

<sup>15</sup> The total input and total output BTU ratings refer to input power to the power supply and output power to the switch. The BTU ratings are based on 100 VAC for the 350-W and 715-W power supplies and 115 VAC for the 1100-W power supply.

<sup>16</sup> The total input and total output BTU ratings refer to input power to the power supply and output power to the switch. The BTU ratings are based on 100 VAC for the 350-W and 715-W power supplies and 115 VAC for the 1100-W power supply.

**Table 36: Power Specifications for DC-Power**

Power Requirements	
Maximum output power	<ul style="list-style-type: none"> <li>• PWR-C1-440WDC: 440 W</li> <li>• PWR-C3-750WDC-R: 750 W</li> <li>• PWR-C3-750WDC-F: 750 W</li> </ul>

Input current	<ul style="list-style-type: none"> <li>• PWR-C1-440WDC: 16 –8 A</li> <li>• PWR-C3-750WDC-R: 25 A</li> <li>• PWR-C3-750WDC-F: 25 A</li> </ul>
DC input voltage	<ul style="list-style-type: none"> <li>• PWR-C1-440WDC: –36 to –72 VDC</li> <li>• PWR-C3-750WDC-R: –36 to –72 VDC</li> <li>• PWR-C3-750WDC-F: –36 to –72 VDC</li> </ul>
Output ratings	<ul style="list-style-type: none"> <li>• PWR-C1-440WDC: –56 V@7.86 A</li> <li>• PWR-C3-750WDC-R: 62 A @ 12 VDC, 3 A @ 3.3 VDC</li> <li>• PWR-C3-750WDC-F: 62 A @ 12 VDC, 3 A @ 3.3 VDC</li> </ul>
Voltage range domestic	<ul style="list-style-type: none"> <li>• PWR-C1-440WDC: –36 VDC (minimum), –48 VDC (nominal), –72 VDC (maximum)</li> <li>• PWR-C3-750WDC-R: –48 VDC (nominal) (-40.5 VDC to -56 VDC)</li> <li>• PWR-C3-750WDC-F: –48 VDC (nominal) (-40.5 VDC to -56 VDC)</li> </ul>
Voltage range international	<ul style="list-style-type: none"> <li>• PWR-C1-440WDC: –36 VDC (minimum), –48 VDC (nominal), –72 VDC (maximum)</li> <li>• PWR-C3-750WDC-R: –60 VDC (nominal) (-55 VDC to -72 VDC)</li> <li>• PWR-C3-750WDC-F: –60 VDC (nominal) (-55 VDC to -72 VDC)</li> </ul>
Total input BTU <sup>17</sup>	PWR-C1-440WDC 1841 BTUs per hour, 540 W
Total output BTU <sup>1</sup>	PWR-C1-440WDC: 1502 BTUs per hour, 440 W
Wire gauge for ground connection	PWR-C1-440WDC: 12 AWG or 8 AWG
Branch circuit protection	PWR-C1-440WDC: 20 A

<sup>17</sup> The total input and total output BTU ratings refer to input power to the power supply and output power to the switch. The BTU ratings are based on –36 VDC.

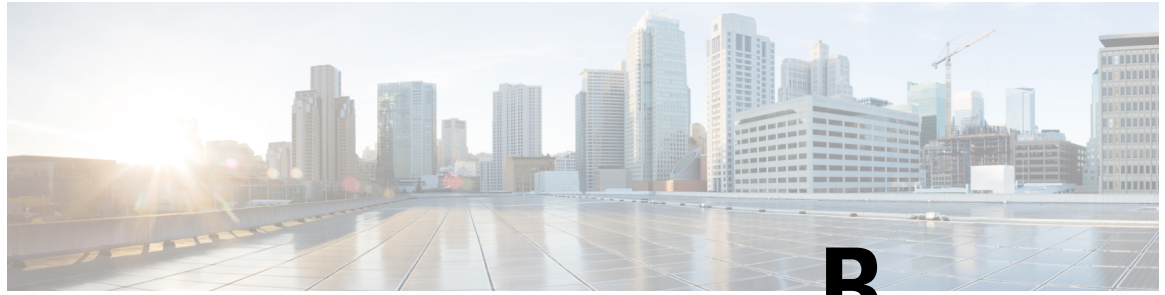
**Table 37: Fan Module Environmental and Physical Specifications for Catalyst WS-C3850 Switch Models**

<b>Environmental Ranges</b>	
Operating temperature	23 to 176°F (–5 to 80°C)

Storage temperature	-40 to 185°F (-40 to 85°C) up to 15,000 ft (4500 m)
Relative humidity	5 to 95% (noncondensing)
Altitude	Up to 13,000 ft (4000 m)
<b>Physical Specification</b>	
Dimensions (H x D x W)	1.62 x 1.73 x 4.24 in. (4.11 x 4.39 x 10.76 cm)
Weight (for three fans)	0.48 lb (0.21 kg)
<b>Operating Specification</b>	
Airflow	20 cfm

**Table 38: Fan Module Environmental and Physical Specifications for Catalyst WS-C3850-48XS Switch Models**

<b>Environmental Ranges</b>	
Operating temperature	50 to 104°F (10 to 40°C)
Relative humidity	8 to 80% (noncondensing)
Altitude	-50 to 6500 feet (-16 to 1981 meters)
<b>Physical Specification</b>	
Dimensions (H x D x W)	2.25 x 7.00 x 8.50 in. (5.72 x 17.78 x 21.59 cm)
Weight	0.7 lb (0.32 kg)



# APPENDIX **B**

## Connector and Cable Specifications

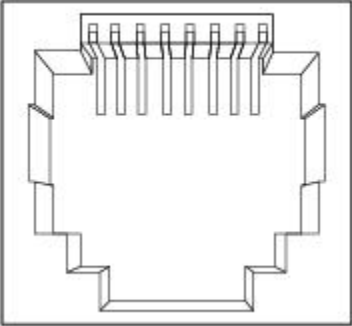
- [Connector Specifications, on page 127](#)
- [Console Port, on page 128](#)
- [Cables and Adapters, on page 129](#)

### Connector Specifications

#### 10/100/1000 Ports (Including PoE)

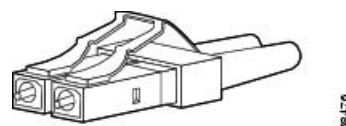
All 10/100/1000 ports use standard RJ-45 connectors and Ethernet pinouts.

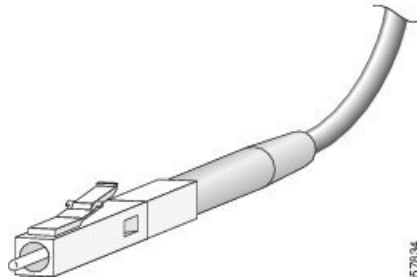
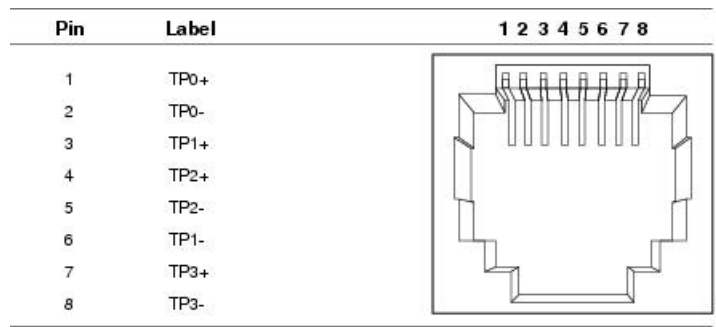
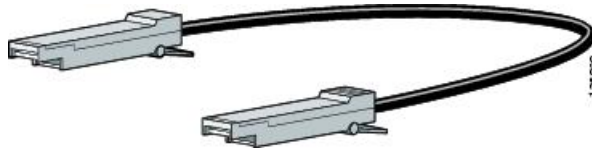
*Figure 86: 10/100/1000 Port Pinouts*

Pin	Label	1 2 3 4 5 6 7 8
1	TP0+	
2	TP0-	
3	TP1+	
4	TP2+	
5	TP2-	
6	TP1-	
7	TP3+	
8	TP3-	

### SFP Module Connectors

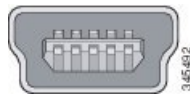
*Figure 87: Duplex LC Cable Connector*



**Figure 88: Simplex LC Cable Connector****Figure 89: Copper SFP Module LC Connector****Figure 90: SFP Module Patch Cable**

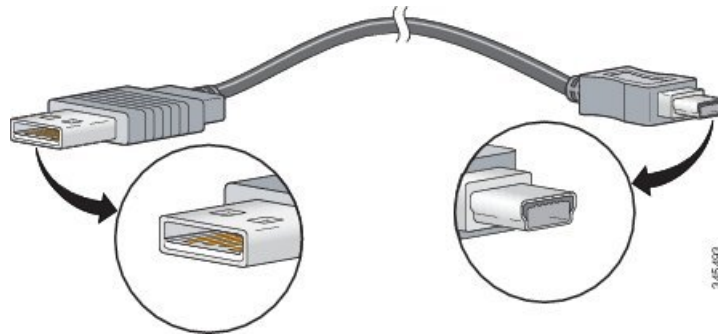
## Console Port

The switch has two console ports: a USB 5-pin mini-Type B port on the front panel and an RJ-45 console port on the rear panel.

**Figure 91: USB Mini-Type B Port**

The USB console port uses a USB Type A to 5-pin mini-Type B cable. The USB Type A-to-USB mini-Type B cable is not supplied. You can order an accessory kit (part number 800-33434) that contains this cable.

Figure 92: USB Type A-to-USB 5-Pin Mini-Type B Cable



The RJ-45 console port uses an 8-pin RJ-45 connection. The supplied RJ-45-to-DB-9 adapter cable is used to connect the console port of the switch to a console PC. You need to provide a RJ-45-to-DB-25 female DTE adapter if you want to connect the switch console port to a terminal.

## Cables and Adapters

### StackWise Cables

You can order these StackWise cables (nonhalogen) from your Cisco sales representative:

- STACK-T1-50CM= (0.5-meter cable)
- STACK-T1-1M= (1-meter cable)
- STACK-T1-3M= (3-meter cable)

Table 39: StackWise Cables Minimum Bend Radius and Coiled Diameter

Cable Part Number	Cable Length	Minimum Bend Radius	Minimum Coiled Diameter
STACK-T1-50CM	1.64 feet (0.5 m)	2.60 in. (66 mm)	5.20 in. (132 mm)
STACK-T1-1M	3.28 feet (1.0 m)	2.60 in. (66 mm)	5.20 in. (132 mm)
STACK-T1-3M	9.84 feet (3.0 m)	3.58 in. (91 mm)	7.17 in. (182 mm)
STACK-T2-50CM	1.64 feet (0.5 m)	2.60 in. (66 mm)	5.20 in. (132 mm)
STACK-T2-1M	3.28 feet (1.0 m)	2.60 in. (66 mm)	5.20 in. (132 mm)
STACK-T2-3M	9.84 feet (3.0 m)	3.58 in. (91 mm)	7.17 in. (182 mm)

### SFP Module Cables

For cabling specifications, refer to the following notes:

- [Cisco SFP and SFP+ Transceiver Module Installation Notes](#)

- [Cisco 40-Gigabit QSFP+ Transceiver Modules Installation Note](#)

Cisco Catalyst 2960-X and 2960-XR Switches now support QSFP-4X10G-AOC5M, the 40GQSFP to four 10G SFP+ direct attach breakout Active Optical cable assembly.

Each port must match the wave-length specifications on the other end of the cable, and the cable must not exceed the stipulated cable length. Copper 1000BASE-T SFP module transceivers use standard four twisted-pair, Category 5 cable at lengths up to 328 feet (100 meters).

## Cisco QSFP to SFP or SFP+ Adapter

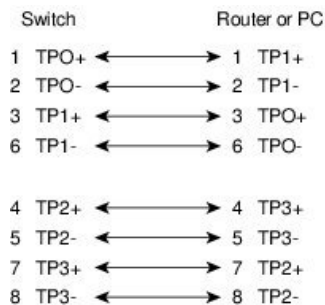
Cisco QSFP to SFP or SFP+ Adapter (QSA) is a pluggable adapter that converts a QSFP port in to an SFP or SFP+ port. You can connect one of the following SFP+ or SFP module or an SFP+ copper.

The following is the list of Cisco SFP or SFP+ transceiver modules that are currently supported.

- Cisco SFP-10G-SR - Cisco 10GBASE-SR SFP+ Module for Multimode Fiber
- Cisco SFP-10G-SR-S module (S-Class) - Cisco 10GBASE-SR SFP+ Module for Multimode Fiber
- Cisco SFP-10G-LR - Cisco 10GBASE-LR SFP+ Module for Single-Mode Fiber
- Cisco SFP-10G-LR-S module (S-Class) - Cisco 10GBASE-LR SFP+ Module for Single-Mode Fiber
- Cisco SFP-10G-ER - Cisco 10GBASE-ER SFP+ Module for Single-Mode Fiber (extended reach)
- Cisco SFP-10G-ER-S module (S-Class) - Cisco 10GBASE-ER SFP+ Module for Single-Mode Fiber (extended reach)
- Cisco SFP-10G-ZR - Cisco 10GBASE-ZR SFP+ Module for Single-Mode Fiber (up to 80 km reach)
- Cisco SFP-10G-ZR-S module (S-Class) - Cisco 10GBASE-ZR SFP+ Module for Single-Mode Fiber (up to 80 km reach)

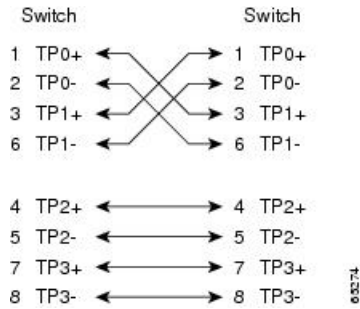
## Cable Pinouts

**Figure 93: Four Twisted-Pair Straight-Through Cable Schematic**

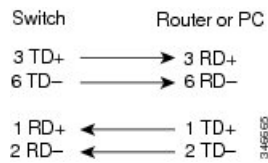


65272

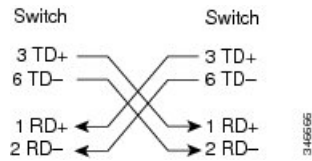
**Figure 94: Four Twisted-Pair Semi-Cross Cable Schematic**



**Figure 95: Two Twisted-Pair Straight-Through Cable Schematic**



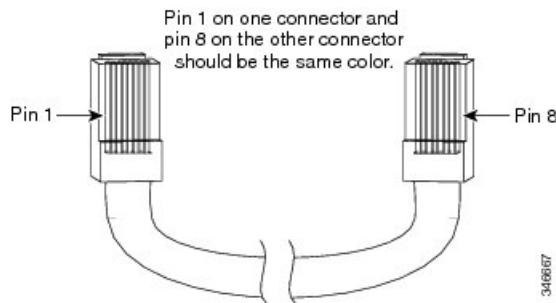
**Figure 96: Two Twisted-Pair Crossover Cable Schematic**



**Identifying a Crossover Cable**

To identify a crossover cable, compare the two modular ends of the cable. Hold the cable ends side-by-side, with the tab at the back. The wire connected to the pin on the outside of the left plug should be a different color from the wire connected to the pin on the inside of the right plug.

**Figure 97: Identifying a Crossover Cable**



**Console Port Adapter Pinouts**

The RS-232 console port uses an 8-pin RJ-45 connector. Use an RJ-45-to-DB-9 adapter cable to connect the switch console port to a console PC. You need to provide a RJ-45-to-DB-25 female DTE adapter to connect the switch console port to a terminal.

*Table 40: Console Port Signaling with a DB-9 Adapter*

Switch Console Port (DTE)	RJ-45-to-DB-9 Terminal Adapter	Console Device
Signal	DB-9 Pin	Signal
RTS	8	CTS
DTR	6	DSR
TxD	2	RxD
GND	5	GND
GND	5	GND
RxD	3	TxD
DSR	4	DTR
CTS	7	RTS

*Table 41: Console Port Signaling with a DB-25 Adapter*

Switch Console Port (DTE)	RJ-45-to-DB-25 Terminal Adapter	Console Device
Signal	DB-25 Pin	Signal
RTS	5	CTS
DTR	6	DSR
TxD	3	RxD
GND	7	GND
GND	7	GND
RxD	2	TxD
DSR	20	DTR
CTS	4	RTS